

SA4110

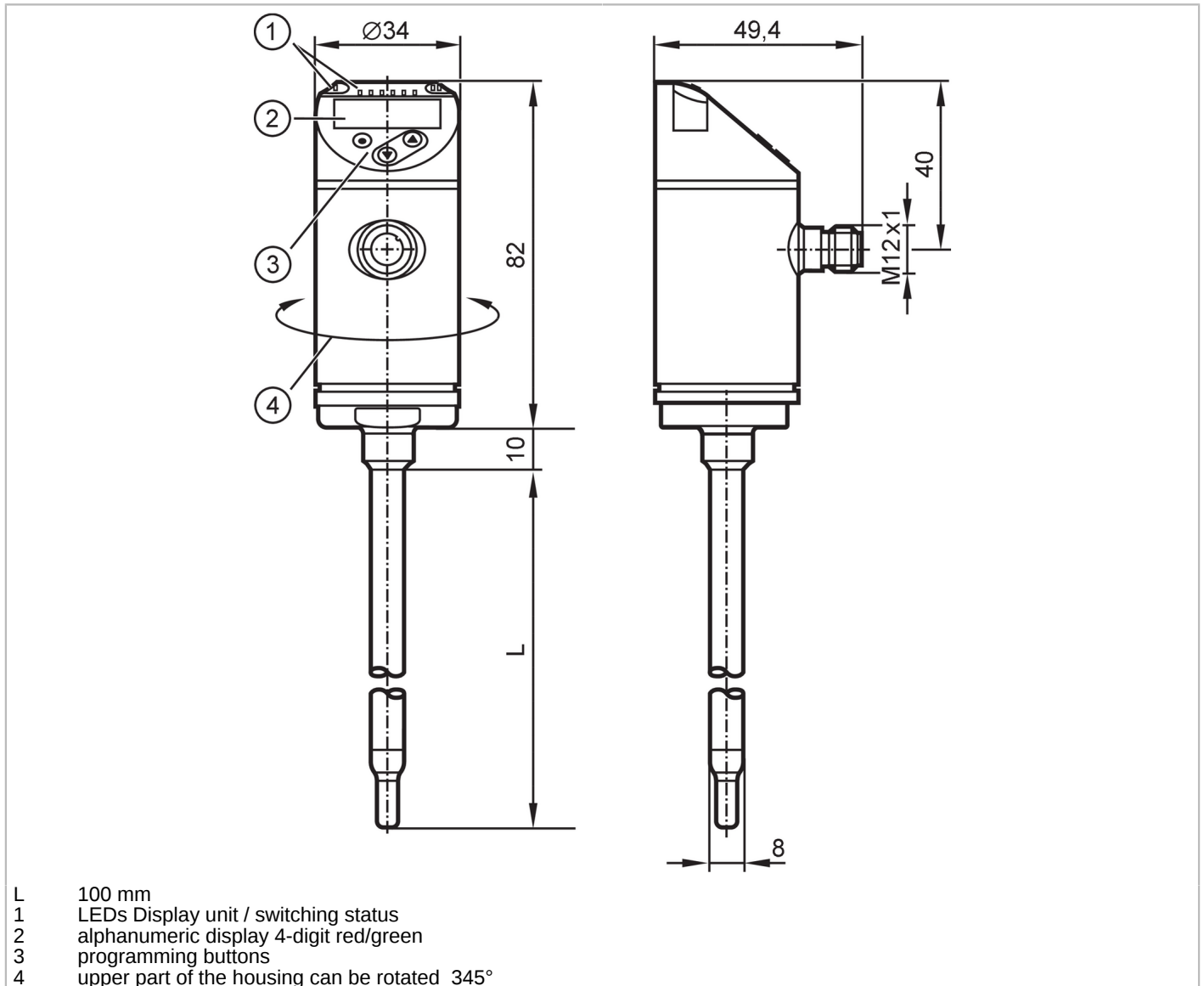

Flow sensor

SAEXXXBFRKG/US-100



Product characteristics			
Number of inputs and outputs	Number of digital outputs: 2; Number of analogue outputs: 1		
Process connection	clamp adapter Ø 8 mm		
Application			
Special feature	Gold-plated contacts		
Media	water; glycol solutions; air; oils		
Note on media	low-viscosity oils with viscosity: ≤ 40 mm ² /s (104 °F) high-viscosity oils with viscosity: > 40 mm ² /s (104 °F)		
Medium temperature [°F]	-4...212		
Pressure rating	50 bar	725 psi	5 MPa
MAWP for applications according to CRN [bar]	50		
Electrical data			
Operating voltage [V]	18...30 DC		

SA4110



Flow sensor

SAEXXXBFRKG/US-100

Current consumption	[mA]	< 100
Protection class		III
Reverse polarity protection		yes
Power-on delay time	[s]	10
Measuring principle		calorimetric

Inputs / outputs

Number of inputs and outputs	Number of digital outputs: 2; Number of analogue outputs: 1
------------------------------	---

Outputs

Total number of outputs	2
Output signal	switching signal; analogue signal; frequency signal; IO-Link; (configurable)
Electrical design	PNP/NPN
Number of digital outputs	2
Output function	normally open / normally closed; (parameterisable)
Max. voltage drop switching output DC	[V] 2.5
Permanent current rating of switching output DC	[mA] 250
Number of analogue outputs	1
Analogue current output	[mA] 4...20; (scalable)
Max. load	[Ω] 350
Short-circuit protection	yes
Type of short-circuit protection	pulsed
Overload protection	yes
Frequency of the output	[Hz] 0...1000

Measuring/setting range

Probe length L	[mm] 100
Operating mode	relative; absolutely liquid; absolutely gaseous; (absolute: reference measurement recommended; Factory setting: relative)

Temperature monitoring

Measuring range	[°F] -4...212
Resolution	[°F] 0.5

Liquid media - absolute operating mode

Setting range	[ft/s] 0.15...9.85
Greatest sensitivity	[ft/s] 0.15...9.85

Liquid media - relative operating mode

Setting range	[ft/s] 0.15...19.5
Greatest sensitivity	[ft/s] 0.15...9.85

Gases - operating mode "absolute"

Setting range	[ft/s] 6...328
Greatest sensitivity	[ft/s] 6...328

Gases - operating mode "relative"

Setting range	[ft/s] 6...656
Greatest sensitivity	[ft/s] 6...328

SA4110



Flow sensor

SAEXXXBFRKG/US-100

Accuracy / deviations		
Temperature drift	[cm/s x 1/K]	0,01 fps x 1/K (< 68 °F; > 158 °F)
Temperature gradient	[K/min]	100
Absolute operating mode		
Repeatability		0,05 m/s; (water; flow velocity: 0,05...3 m/s)
Relative operating mode		
Accuracy		± (7 % MW + 2 % MEW); (for relative mode in the range of maximum sensitivity under the following conditions:; water: 68...158 °F; inlet length: 5 ft; DN25 (DIN 2448); mounting position according to instructions; Accuracy can differ for other media and mounting positions.)
Repeatability		0,05 m/s; (water; flow velocity: 0,05...3 m/s)
Temperature monitoring		
Temperature drift		± 0,003 K/°F
Accuracy	[K]	± 0,3 / ± 1; (water; flow velocity: 1...9,85 fps / air; flow velocity: > 32,8 fps)
Response times		
Response time	[s]	0.5; (T09; water; glycol: 0,8 s; air: 7 s; oil: 1,8 s; each T09)
Temperature monitoring		
Dynamic response T05 / T09	[s]	1,5 (T09); (water; flow velocity: 1...9,85 fps)
Software / programming		
Parameter setting options		hysteresis / window; normally open / normally closed; switching logic; current/frequency output; medium selection; Damping; Teach function; display can be rotated and switched off; standard unit of measurement; process value colour
Interfaces		
Communication interface		IO-Link
Transmission type		COM2 (38,4 kBaud)
IO-Link revision		1.1
SDCI standard		IEC 61131-9
Profiles	Smart Sensor - SSP 0	Generic Profiled Sensor
	Function	Device identification
	Function	Process data variable
	Function	Device diagnosis
SIO mode		yes
Required master port type		A
Process data analogue		2
Process data binary		2
Min. process cycle time	[ms]	3
Supported DeviceIDs	Type of operation	DeviceID
	Factory setting / ModE = (REL)	537
	ModE = (GAS)	551
	ModE = (LIQU)	544
Operating conditions		
Ambient temperature	[°F]	-40...176
Storage temperature	[°F]	-40...212
Protection		IP 65; IP 67

SA4110



Flow sensor

SAEXXXBFRKG/US-100

Tests / approvals		
EMC	DIN EN 60947-5-9	
Shock resistance	DIN EN 60068-2-27	50 g (11 ms)
Vibration resistance	DIN EN 60068-2-6	5 g (10...2000 Hz)
MTTF [years]		143
UL approval	UL approval no.	I017
	File number UL	E174189

Mechanical data		
Weight [g]		241.4
Housing		cylindrical
Dimensions [mm]		Ø 8 / L = 192
Materials		stainless steel (316L/1.4404); PBT-GF20; PBT-GF30
Materials (wetted parts)		stainless steel (316L/1.4404)
Process connection		clamp adapter Ø 8 mm

Displays / operating elements		
Display	Display unit	6 x LED, green (% , fps, gpm, cfm, °F, 10 ³)
	switching status	2 x LED, yellow
	measured values	alphanumeric display, red/green 4-digit

Remarks		
Remarks		MW = measured value MEW = Final value of the measuring range
Pack quantity		1 pcs.

Electrical connection

Connector: 1 x M12; coding: A; Contacts: gold-plated



SA4110



Flow sensor

SAEXXXBFRKG/US-100

Connection



colours to DIN EN 60947-5-2

OUT1:

- switching output volumetric flow quantity monitoring
- frequency output volumetric flow quantity monitoring
- IO-Link

OUT2:

- switching output volumetric flow quantity monitoring
- switching output Temperature monitoring
- analogue output volumetric flow quantity monitoring
- analogue output Temperature monitoring
- frequency output volumetric flow quantity monitoring
- frequency output Temperature monitoring
- input External Teach

Core colours :

- BK = black
- BN = brown
- BU = blue
- WH = white