

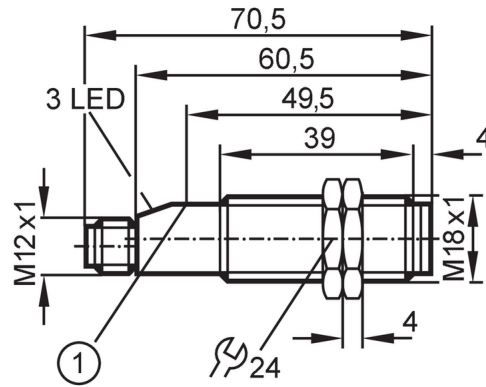

Diffuse reflection sensor with background suppression

OGH-FPKG/V4A/US-100



1 pushbutton



Product characteristics

Type of light	red light
Housing	threaded type

Application

Special feature	Gold-plated contacts; Background suppression
Function principle	Diffuse reflection sensor

Electrical data

Operating voltage [V]	10...36 DC
Current consumption [mA]	< 40
Protection class	II
Reverse polarity protection	yes
Type of light	red light
Wave length [nm]	660

Outputs

Electrical design	PNP
Output function	light-on/dark-on mode; (programmable)
Max. voltage drop switching output DC [V]	2.5
Permanent current rating of switching output DC [mA]	150; (200 (...60 °C))
Switching frequency DC [Hz]	250
Short-circuit protection	yes
Type of short-circuit protection	pulsed
Overload protection	yes

Detection zone

Range [mm]	30...130; (white paper 200 x 200 mm 90% remission)
Range adjustable	yes
Max. light spot diameter [mm]	12
Light spot dimensions refer to	at maximum range
Background suppression available	yes

OG5119



Diffuse reflection sensor with background suppression

OGH-FPKG/V4A/US-100

Operating conditions		
Ambient temperature	[°C]	-20...80
Protection		IP 68; IP 69K
Tests / approvals		
EMC	EN 60947-5-2	
	EN 55011	class B
MTTF	[years]	521
Mechanical data		
Weight	[g]	60
Housing		threaded type
Dimensions	[mm]	M18 x 1 / L = 70.5
Thread designation		M18 x 1
Materials		housing: stainless steel (316L/1.4404); End cap: PBT
Lens material		front pane:PMMA
Displays / operating elements		
Display	switching status	1 x LED, yellow
	operation	1 x LED, green
	function	1 x LED, red
Accessories		
Items supplied		lock nuts: 2
Remarks		
Remarks		operating voltage "supply class 2" according to cULus
Pack quantity		1 pcs.
Electrical connection		

Connector: 1 x M12; coding: A; Contacts: gold-plated



Connection

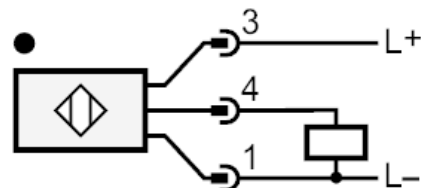
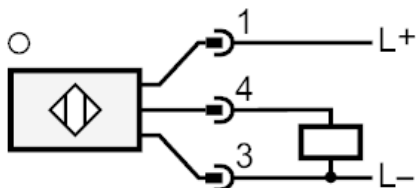



Diffuse reflection sensor with background suppression

OGH-FPKG/V4A/US-100

Diagrams and graphs

accuracy graph

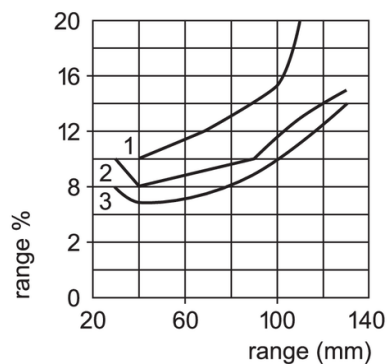

x: distance sensor/object [mm]

y: min. distance object/background [mm]

1 = object black (6 % remission) , background white (90 % remission)

2 = object grey (18 % remission) , background white (90 % remission)

3 = object white (90 % remission) , background white (90 % remission)

Note : range % = setting in % of the range