

# OGT200

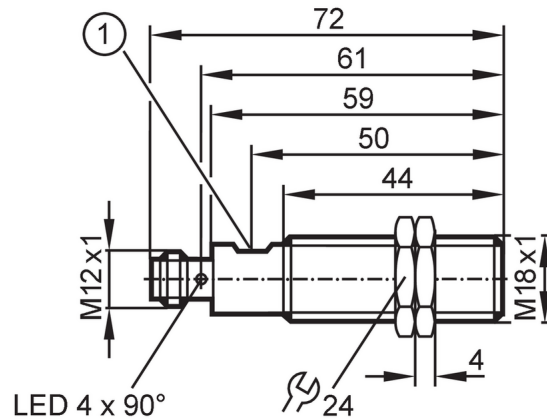

## Diffuse reflection sensor

OGT-HPKG/US100



1 potentiometer



### Product characteristics

Type of light	red light
Housing	threaded type

### Application

Function principle	Diffuse reflection sensor
Application	Industrial applications / factory automation

### Electrical data

Operating voltage [V]	10...36 DC; ("supply class 2" to cULus)
Current consumption [mA]	20
Protection class	II
Reverse polarity protection	yes
Type of light	red light
Wave length [nm]	624

### Outputs

Electrical design	PNP
Output function	light-on mode
Max. voltage drop switching output DC [V]	2.5
Permanent current rating of switching output DC [mA]	200
Switching frequency DC [Hz]	800
Short-circuit protection	yes
Type of short-circuit protection	pulsed
Overload protection	yes

### Detection zone

Range [mm]	2...600; (white paper 200 x 200 mm 90% remission)
Setting range [mm]	150...600
Range adjustable	yes
Max. light spot diameter [mm]	50
Light spot dimensions refer to	at maximum range

# OGT200



## Diffuse reflection sensor

OGT-HPKG/US100

Operating conditions		
Ambient temperature	[°C]	-25...60
Protection		IP 65
Tests / approvals		
EMC		EN 60947-5-2
MTTF	[years]	428
Mechanical data		
Weight	[g]	53.6
Housing		threaded type
Dimensions	[mm]	M18 x 1 / L = 72
Thread designation		M18 x 1
Materials		housing: stainless steel (316L/1.4404); operator interface: TPE
Lens material		front pane:PMMA
Displays / operating elements		
Display	switching status	1 x LED, yellow
Operating elements		potentiometer
Accessories		
Items supplied		lock nuts: 2
Remarks		
Pack quantity		1 pcs.

### Electrical connection

Connector: 1 x M12; coding: A; Contacts: 4



### Connection

