

# OGH200

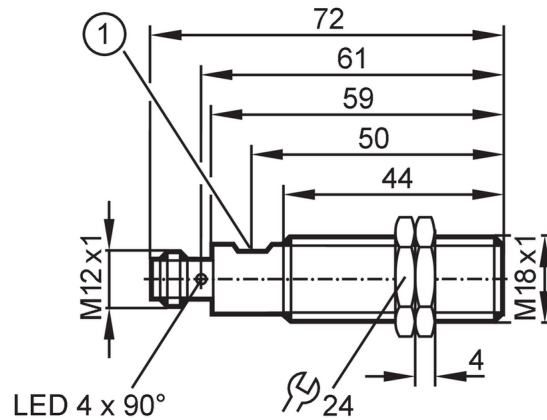

## Diffuse reflection sensor with background suppression

OGH-HPKG/US100



1 potentiometer



### Product characteristics

Type of light	red light
Housing	threaded type

### Application

Special feature	Background suppression
Function principle	Diffuse reflection sensor
Application	Industrial applications / factory automation

### Electrical data

Operating voltage [V]	10...36 DC
Current consumption [mA]	25
Protection class	II
Reverse polarity protection	yes
Type of light	red light
Wave length [nm]	624

### Outputs

Electrical design	PNP
Output function	light-on mode
Max. voltage drop switching output DC [V]	2.5
Permanent current rating of switching output DC [mA]	200
Switching frequency DC [Hz]	1000
Short-circuit protection	yes
Type of short-circuit protection	pulsed
Overload protection	yes

### Detection zone

Range [mm]	15...250; (white paper 200 x 200 mm 90% remission)
Range on white object (90 % remission) [mm]	15...250

# OGH200



## Diffuse reflection sensor with background suppression

OGH-HPKG/US100

Range on grey object (18 % remission) [mm]	15...230
Range on black object (6 % remission) [mm]	15...160
Range adjustable	yes
Max. light spot diameter [mm]	21
Light spot dimensions refer to	at maximum range
Background suppression available	yes

### Operating conditions

Ambient temperature [°C]	-25...60
Protection	IP 65

### Tests / approvals

EMC	EN 60947-5-2
MTTF [years]	339

### Mechanical data

Weight [g]	53.25
Housing	threaded type
Dimensions [mm]	M18 x 1 / L = 72
Thread designation	M18 x 1
Materials	housing: stainless steel; operator interface: TPE
Lens material	front pane:PMMA

### Displays / operating elements

Display	switching status	1 x LED, yellow
Operating elements		potentiometer

### Accessories

Items supplied	lock nuts: 2
----------------	--------------

### Remarks

Remarks	operating voltage "supply class 2" according to cULus
Pack quantity	1 pcs.

### Electrical connection

Connector: 1 x M12; coding: A; Contacts: 4



## Diffuse reflection sensor with background suppression

OGH-HPKG/US100

### Connection

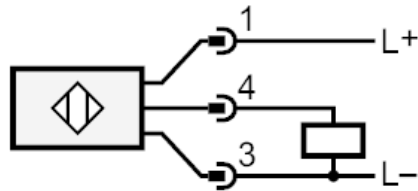

### Diagrams and graphs

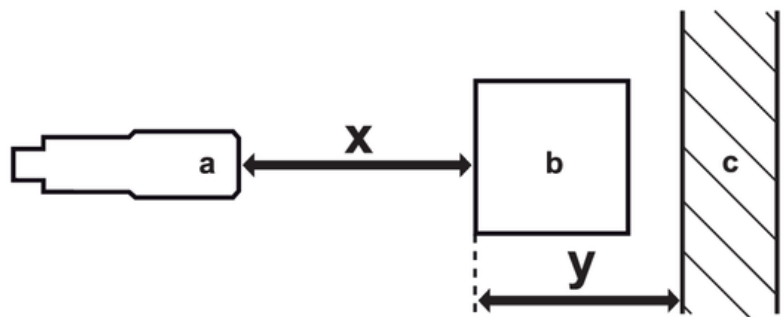

- a: sensor
- b: object
- c: background
- x: distance sensor/object [mm]
- y: min. distance object/background [mm]



## Diffuse reflection sensor with background suppression

OGH-HPKG/US100

accuracy graph

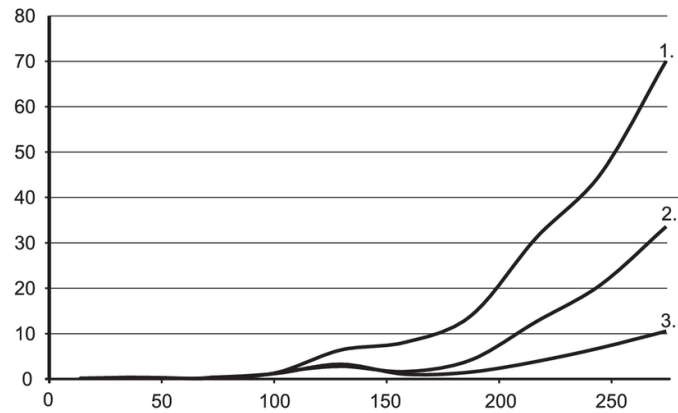

x: distance sensor/object [mm]

y: min. distance object/background [mm]

1 = object black (6 % remission) , background white (90 % remission)

2 = object grey (18 % remission) , background white (90 % remission)

3 = object white (90 % remission) , background white (90 % remission)