

OGE700

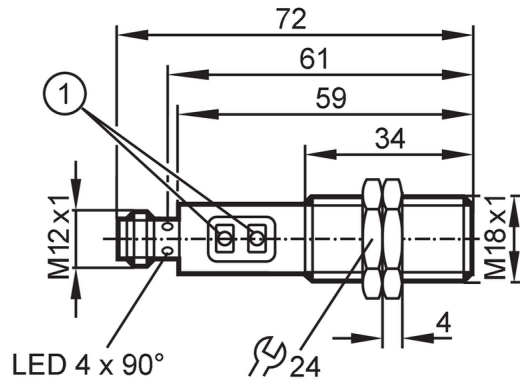

Through-beam laser sensor receiver

OGELFPKG/US100



1 programming buttons



Product characteristics

Type of light	red light
Housing	threaded type

Application

Function principle	Through-beam sensor
Application	Industrial applications / factory automation

Electrical data

Operating voltage	[V]	10...36 DC
Current consumption	[mA]	11
Protection class		II
Reverse polarity protection		yes
Type of light		red light
Wave length	[nm]	655
Typ. lifetime	[h]	50000

Outputs

Electrical design		PNP
Output function		light-on/dark-on mode; (programmable)
Max. voltage drop switching output DC	[V]	2.5
Permanent current rating of switching output DC	[mA]	200
Switching frequency DC	[Hz]	1000
Short-circuit protection		yes
Type of short-circuit protection		pulsed
Overload protection		yes

Detection zone

Transmitter / receiver		receiver
Range	[m]	< 60
Factory setting		dark-on mode
Range adjustable		yes

OGE700



Through-beam laser sensor receiver

OGELFPKG/US100

Diameter of the smallest detectable object	[mm]	3; (60 m)
--	------	-----------

Operating conditions

Ambient temperature	[°C]	-10...60
Protection		IP 65; IP 67

Tests / approvals

EMC		EN 60947-5-2
MTTF	[years]	786

Mechanical data

Weight	[g]	61.9
Housing		threaded type
Dimensions	[mm]	M18 x 1 / L = 72
Thread designation		M18 x 1
Materials		stainless steel (316L/1.4404); PA; LCP; EPDM; TPU
Lens material		front pane:PMMA

Displays / operating elements

Display	switching status	1 x LED, yellow
---------	------------------	-----------------

Accessories

Items supplied		lock nuts: 2
----------------	--	--------------

Remarks

Remarks		operating voltage "supply class 2" according to cULus
Pack quantity		1 pcs.

Electrical connection

Connector: 1 x M12; coding: A; Contacts: 4



Connection

