

O5S500

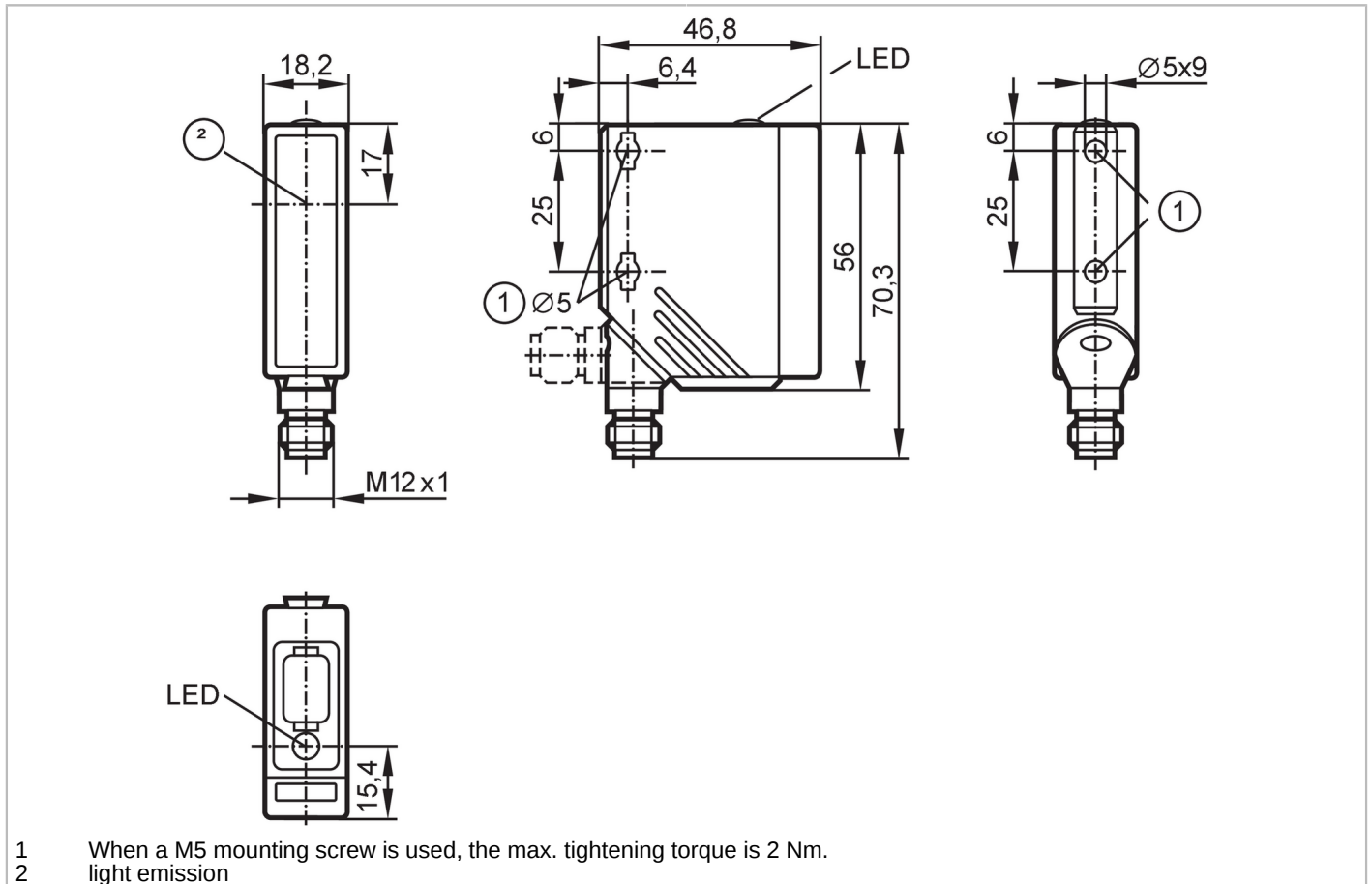

Through-beam sensor transmitter

O5S-00KG/US100



Product characteristics	
Type of light	red light
Housing	rectangular
Application	
Function principle	Through-beam sensor
Application	Industrial applications / factory automation
Electrical data	
Operating voltage [V]	10...36 DC
Current consumption [mA]	20
Protection class	II
Reverse polarity protection	yes
Type of light	red light
Wave length [nm]	624
Detection zone	
Transmitter / receiver	transmitter
Range [m]	< 25
Range adjustable	no
Max. light spot diameter [mm]	625
Light spot dimensions refer to	at maximum range

O5S500



Through-beam sensor transmitter

O5S-OOKG/US100

Operating conditions		
Ambient temperature	[°C]	-25...60
Protection		IP 67
Tests / approvals		
EMC		EN 60947-5-2
MTTF	[years]	617
Mechanical data		
Weight	[g]	65.5
Housing		rectangular
Dimensions	[mm]	56 x 18.2 x 46.8
Materials		housing: PA; bezel: stainless steel; operator interface: TPU
Lens material		front pane:PMMA
Lens alignment		side lens
Displays / operating elements		
Display	operation	1 x LED, green
Remarks		
Remarks		operating voltage "supply class 2" according to cULus
Pack quantity		1 pcs.
Electrical connection		

Connector: 1 x M12; coding: A; Contacts: 4



Connection

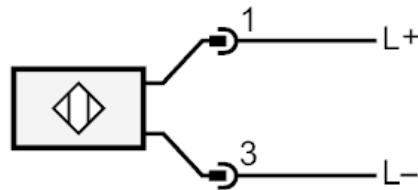

O5S500



Through-beam sensor transmitter

O5S-OOKG/US100

Diagrams and graphs

excess gain graph

