

# O3D312

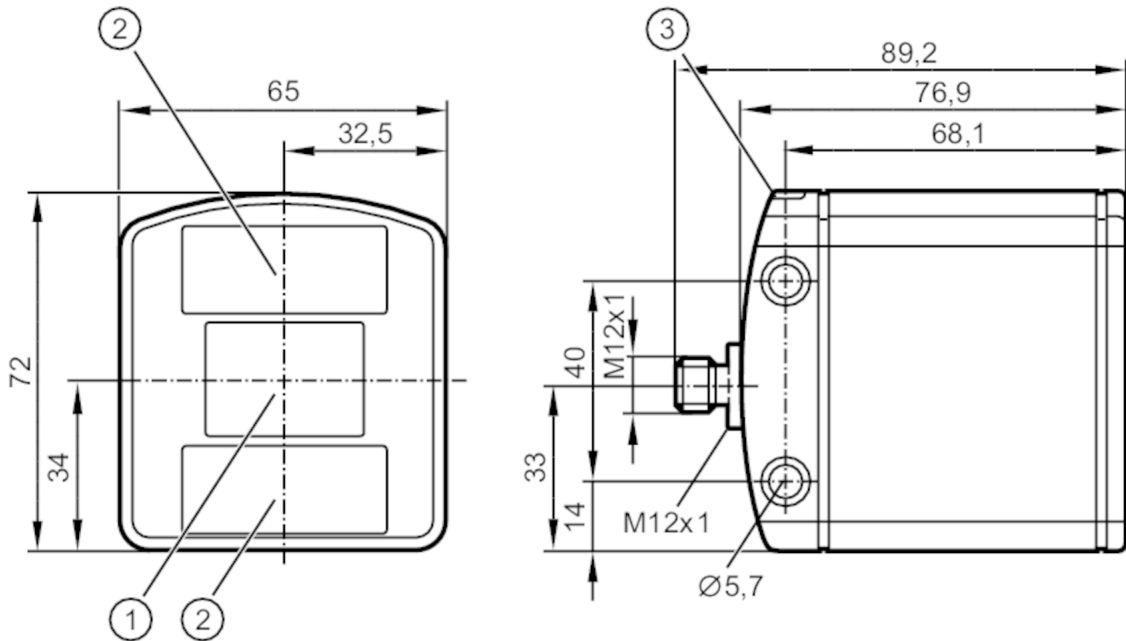

## 3D sensor

O3DIRDKG/E1/GM/SI/60



- 1 lens
- 2 Illumination unit
- 3 LED 2-colour yellow/green



### Product characteristics

Type of light	infrared light
Image resolution 3D [px]	176 x 132
Angle of aperture 3D [°]	60 x 45; (nominal value without lens distortion correction)
Image repetition frequency 3D [Hz]	25

### Application

Application	dimensioning of the object; completeness monitoring; Level monitoring; distance monitoring; volume monitoring; robot gripper navigation; depalletizing
-------------	--

### Electrical data

Operating voltage [V]	20.4...28.8 DC; (EN 61131-2)
Current consumption [mA]	420; (maximum mean value: < 1600 mA)
Max. current consumption [mA]	2400; (peak current pulsed)
Power consumption [W]	10; (typical value)
Protection class	III
Type of light	infrared light
Image sensor	PMD 3D ToF-Chip
Internal lighting	yes; (infrared: 850 nm invisible radiation LED)

### Inputs / outputs

Number of inputs and outputs	Number of digital inputs: 2; Number of digital outputs: 3; Number of analogue outputs: 1
------------------------------	--



## 3D sensor

O3DIRDKG/E1/GM/S/60

Inputs	
Trigger	24 V PNP/NPN (IEC 61131-2 Typ 3)
Number of digital inputs	2
Input circuit of digital inputs	24 V PNP/NPN; (configurable; IEC 61131-2 Typ 3)
Outputs	
Total number of outputs	3
Number of digital outputs	3; (configurable)
Output function	24 V PNP/NPN; (EN 61131-2)
Max. voltage drop switching output DC [V]	1
Max. current load per output [mA]	100
Number of analogue outputs	1; (configurable)
Analogue current output [mA]	4...20
Max. load [Ω]	500
Analogue voltage output [V]	0...10
Min. load resistance [Ω]	10000
Precision analogue output [%]	1
Short-circuit protection	yes
Type of short-circuit protection	pulsed
Overload protection	yes
Resolution of analogue output	12 bit
Detection zone	
Operating distance [mm]	300...8000
Note on operating distance	object size: 200 x 200 mm reflectivity: 18 %
Image resolution 3D [px]	176 x 132
Angle of aperture 3D [°]	60 x 45; (nominal value without lens distortion correction)
Image repetition frequency 3D [Hz]	25
Measuring/setting range	
Measuring range [m]	< 30
Software / programming	
Parameter setting options	via PC with ifm Vision Assistant
Interfaces	
Communication interface	Ethernet
Ethernet	
Transmission standard	10Base-T; 100Base-TX
Transmission rate	10; 100
Protocol	TCP/IP; EtherNet/IP; PROFINET
Factory settings	IP address: 192.168.0.69 subnet mask: 255.255.255.0 gateway IP address: 192.168.0.201

# O3D312



## 3D sensor

O3DIRDKG/E1/GM/S/60

Ethernet - EtherNet/IP		
Usage type		data transmission
Ethernet - PROFINET		
Usage type		data transmission
Ethernet - TCP/IP		
Usage type		parameter setting; data transmission
<b>Operating conditions</b>		
Ambient temperature	[°C]	-10...50
Storage temperature	[°C]	-40...85
Protection		IP 65; IP 67; IP 69K
Max. immunity to extraneous light	[klx]	8; (with reduced measuring accuracy and repeatability: < 100)
<b>Tests / approvals</b>		
EMC	DIN EN 61000-6-4	radiation of interference / industrial environments
	DIN EN 61000-6-2	immunity / industrial environments
Shock resistance	DIN EN 60068-2-27	50 g / (11 ms) not repetitive
	DIN EN 60068-2-27	40 g / (6 ms) repetitive
Vibration resistance	DIN EN 60068-2-6	2 g / (10...150 Hz)
	DIN EN 60068-2-64	2.3 g RMS / (10...500 Hz)
Photobiological safety		exempt group; (DIN EN 62471)
Electrical safety	DIN EN 61010-2-201	electrical supply only via PELV circuits
<b>Mechanical data</b>		
Weight	[g]	1212
Dimensions	[mm]	72 x 65 x 89.2
Materials		housing: stainless steel (316L/1.4404); front pane: PMMA; function display: PA
Tightening torque	[Nm]	< 0.8
<b>Displays / operating elements</b>		
Display	function	2 x LED, green Ethernet operation
	switching status	2 x LED, yellow OUT 1 OUT 2
<b>Accessories</b>		
Items supplied		Protective covers
<b>Remarks</b>		
Pack quantity		1 pcs.

# O3D312



## 3D sensor

O3DIRDKG/E1/GM/S/60

### Electrical connection - Ethernet

Connector: 1 x M12; coding: D



1	TD +
2	RD +
3	TD -
4	RD -

### Electrical connection - Process connection

Connector: 1 x M12; coding: A

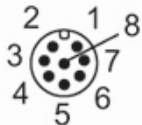

1	U+
2	trigger input
3	GND
4	switching output 1 digital or analogue
5	switching output 3 digital Ready
6	switching output 2 digital
7	switching input 1 digital
8	switching input 2 digital

### Other data

#### field of view size with lens distortion correction

measuring range / distance [m]	Length [m]	Width [m]
0.50	0.37	0.50
1.00	0.75	1.00
2.00	1.50	2.00
3.00	2.25	3.00
4.00	3.00	4.00
5.00	3.75	5.00



## 3D sensor

O3DIRDKG/E1/GM/S/60

### Accuracy of dimensioning of the object

measuring range / distance [m]	accuracy object size (Length, Width, Height) [mm]	accuracy object position (X, Y, Z coordinates) [mm]	accuracy angle of rotation [°]
typical value	typical value	typical value	typical value
1.0...3.0	± 10	± 5	± 1
Operating distance:	0.3 ... 5 m		
Image repetition frequency:	1 Hz		
information applies for:	rectangular objects		
reflectivity:	6...90 % for non-glossy objects		
minimum object size:	100x100x100 mm		
object in centre of the image			
object speed:	< 0.2 m/s		

### completeness monitoring

	object speed < 0.2 m/s [mm]	object speed > 0.2 m/s [mm]
typical value:		
minimum height	25	45
Image repetition frequency [Hz]	5	
Operating distance [m]	0.3...5	
max. packaging size (orthogonal packaging arrangement)	maximum number of objects 64	
The image repetition frequency is reduced by using the position tracking function		

### level and distance monitoring

measuring range / distance [m]	repeatability of the measured distance values on grey objects (18% reflectivity) [mm]	repeatability of ROI of 50x50 pixels on grey objects [mm]	accuracy (reflectivity 6-90%) [mm]
	typical value	typical value	typical value
0.3...1.0	8	0.3	± 7
1.0...3.0	12	0.4	± 7
3.0...5.0	20	0.7	± 10
5.0...7.0	30	1.0	± 15
7.0...8.0	50	1.7	± 20
measured in the centre of the image at an ambient temperature of 20°C			
Repeatability	1 $\sigma$		
The repeatability can be optimised with filter functions			
Temperature drift -10...+50 °C	0.2 mm/K		

# O3D312



## 3D sensor

O3DIRDKG/E1/GM/S/60

### robot gripper navigation and depalletizing

	robot gripper navigation	depalletizing
Operating distance [m]	0.2...6	0.5...6
object types	any object shape	closed rectangular objects
minimum object size [mm]	20 x 20 x 20	50 x 50 x 50 at minimum operating distance
accuracy object position [mm]		
typical value:	± 10 rectangular objects	± 15
accuracy angle of rotation [°]		
typical value:	± 1 rectangular objects	± 3
object speed [m/s]	< 0.2	
Image repetition frequency [Hz]	2 for one object to be measured	1
maximum number of objects	20	