

LMT121

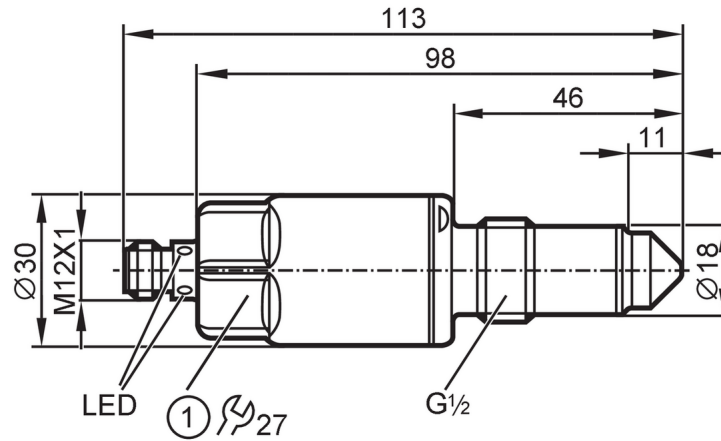

Sensor for point level detection

LMACE-A12E-QSKG-2/US



1 Tightening torque 20...25 Nm



ACS



CRN



EC 1935/2004

EHDG Certified

FCM



IO-Link

Reg31



Product characteristics

Number of inputs and outputs	Number of digital outputs: 2
Factory setting	media with low water content
Process connection	threaded connection G 1/2 sealing cone

Application

Special feature	Gold-plated contacts
Media	Fluessige_Medien pastoese_Medien; powder
Cannot be used for	See the operating instructions, chapter "Function and features".
Probe length [mm]	11
Tank pressure	-1...40; (MAWP for applications according to CRN: 40 bar / 4 MPa) bar
MAWP for applications according to CRN [bar]	-0.1...4; (MAWP for applications according to CRN: 40 bar / 4 MPa) MPa

Oil	
Medium temperature [°C]	-40...100
Medium temperature short time [°C]	-40...150; (1 h)
Water	
Medium temperature [°C]	-40...100
Medium temperature short time [°C]	-40...150; (1 h)

Electrical data

Operating voltage [V]	18...30 DC
Current consumption [mA]	< 50
Protection class	III
Reverse polarity protection	yes
Measuring principle	capacitive

Inputs / outputs

Number of inputs and outputs	Number of digital outputs: 2
------------------------------	------------------------------

LMT121



Sensor for point level detection

LMACE-A12E-QSKG-2/US

Outputs		
Total number of outputs	2	
Output signal	switching signal; IO-Link	
Electrical design	PNP/NPN	
Number of digital outputs	2	
Output function	normally open / normally closed; (parameterisable)	
Max. voltage drop switching output DC [V]	2.5	
Permanent current rating of switching output DC [mA]	100	
Short-circuit protection	yes	
Type of short-circuit protection	pulsed	
Overload protection	yes	
Measuring/setting range		
Factory setting	media with low water content	
Response times		
Response time [s]	< 0.5	
Interfaces		
Communication interface	IO-Link	
Transmission type	COM2 (38,4 kBaud)	
IO-Link revision	1.1	
SDCI standard	IEC 61131-9	
SIO mode	yes	
Required master port type	A	
Process data analogue	1	
Process data binary	2	
Min. process cycle time [ms]	2.3	
Supported DeviceIDs	Type of operation default	DeviceID 306
Operating conditions		
Ambient temperature [°C]	-40...85	
Note on ambient temperature	Medium temperature: < 100 °C -40...60 °C Medium temperature: < 150 °C	
Storage temperature [°C]	-40...85	
Protection	IP 68; IP 69K	
Tests / approvals		
EMC	DIN EN 61000-6-2	
	DIN EN 61000-6-4	: open tanks
	DIN EN 61000-6-3	: closed tanks
Shock resistance	DIN EN 60068-2-27	50 g (11 ms)
Vibration resistance	DIN EN 60068-2-6	20 g (10...2000 Hz)
MTTF [years]	223	
UL approval	UL approval no.	H001

LMT121



Sensor for point level detection

LMACE-A12E-QSKG-2/US

Mechanical data	
Weight [g]	211
Dimensions [mm]	Ø 30 / L = 113
Materials	stainless steel (316L/1.4404); PEEK; PEI; FKM
Materials (wetted parts)	PEEK surface characteristics: Ra < 0,8 µm / Rz = 4 µm
Process connection	threaded connection G 1/2 sealing cone

Displays / operating elements		
Display	switching status	LED, yellow
	operating status	LED, green

Remarks	
Pack quantity	1 pcs.

Electrical connection

Connector: 1 x M12; coding: A; Contacts: gold-plated



Connection

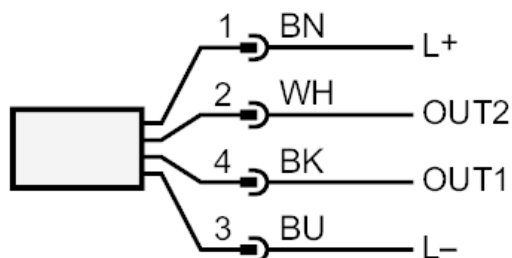

- OUT1: switching output IO-Link Teach
 - OUT2: switching output
- colours to DIN EN 60947-5-2
Core colours :
- BK = black
 - BN = brown
 - BU = blue
 - WH = white