

# LDL101



## Conductive conductivity sensor

COND CONDUCTIVITY UPW HYG G1/2

Digital meets analogue: integrating modern IO-Link sensors the analogue way. The EIO104 allows you to realise two analogue signals from intelligent IO-Link sensors with several process values.

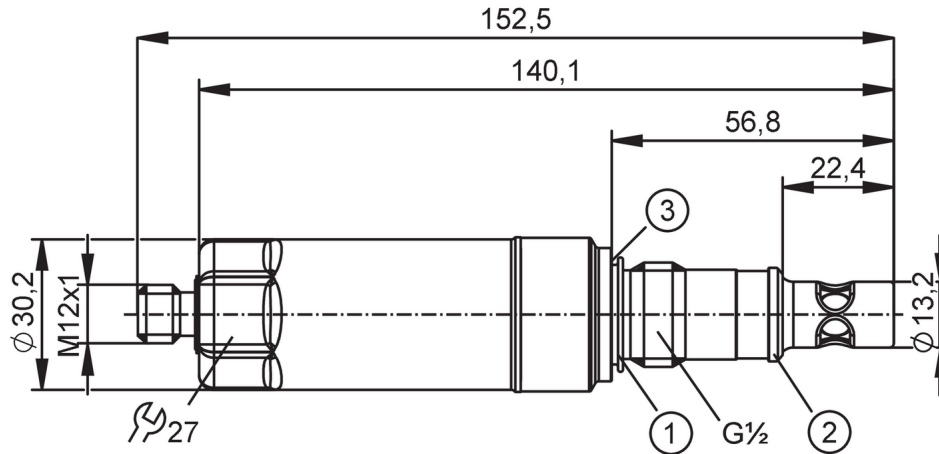

- 1 Gasket FKM (for sealing on the back - not pressure resistant) / removable
- 2 pre-mounted PEEK sealing ring (removable) / metallic sealing area
- 3 groove for sealing ring DIN 3869-21



EC 1935/2004

EHDG Certified

FCM



IO-Link



### Product characteristics

Number of inputs and outputs	Number of analogue outputs: 1
Process connection	threaded connection G 1/2 external thread sealing cone optional:hygienic PEEK gasket according to EHEDG

### Application

Special feature	Gold-plated contacts
Media	conductive liquids
Note on media	ultra-pure water
Cannot be used for	See the operating instructions, chapter "Function and features".
Medium temperature [°C]	-25...100; (< 1 h: 150)
Pressure rating	35 bar      3.5 MPa
Vacuum resistance	-1000 mbar      -0.1 MPa

### Electrical data

Operating voltage [V]	18...30 DC
Current consumption [mA]	< 60
Protection class	III
Reverse polarity protection	yes
Power-on delay time [s]	2
Measuring principle	konduktiv

### Inputs / outputs

Number of inputs and outputs	Number of analogue outputs: 1
------------------------------	-------------------------------

### Outputs

Total number of outputs	1
Output signal	analogue signal; IO-Link
Output function	analogue output scalable; selectable conductivity / temperature
Number of analogue outputs	1

# LDL101



## Conductive conductivity sensor

COND CONDUCTIVITY UPW HYG G1/2

Analogue current output	[mA]	4...20
Max. load	[Ω]	500

### Measuring/setting range

Conductivity measurement			
Measuring range	[μS/cm]	0.04...1000	
Resolution	[μS/cm]	0...9,999	0.001
		10...99,99	0.01
		100...1000	0.1

Temperature measurement		
Measuring range	[°C]	-25...150

### Accuracy / deviations

Conductivity measurement		
Accuracy (in the measuring range)	3 % MW ± 0,03 μS/cm	
Drift	[%/K]	0,1 %/K MW
Repeatability	1 % MW ± 0,010 μS/cm	
Long-term stability	1,5 % MW ± 0,015 μS/cm	

Temperature measurement		
Accuracy	[K]	20...50 °C: < ± 0,5 K; -25...150 °C: < ± 1,5 K
Repeatability	[K]	0,2
Resolution	[K]	0.1

### Response times

Conductivity measurement		
Response time	[s]	< 2; (T09; Damping = 0)

Temperature measurement		
Response time	[s]	< 9; (T09)

### Interfaces

Communication interface	IO-Link	
Transmission type	COM2 (38,4 kBaud)	
IO-Link revision	1.1	
SDCI standard	IEC 61131-9	
Profiles	Smart Sensor - SSP 3.1	Measuring Sensor
	Common - I&D	Identification and Diagnosis
SIO mode	no	
Required master port type	A	
Process data analogue	1	
Min. process cycle time	[ms]	6.4
Supported DeviceIDs	<b>Type of operation</b>	<b>DeviceID</b>
	default	1455

### Operating conditions

Ambient temperature	[°C]	-40...60
Storage temperature	[°C]	-40...85
Protection	IP 68; IP 69K; (7 days / 3 m water depth / 0.3 bar: IP 68)	

# LDL101



## Conductive conductivity sensor

COND CONDUCTIVITY UPW HYG G1/2

Tests / approvals		
EMC	DIN EN 61000-6-2	
	DIN EN 61000-6-3	
Shock resistance	DIN EN 60068-2-27	50 g (11 ms)
Vibration resistance	DIN EN 60068-2-6	20 g (10...2000 Hz)
MTTF [years]		173
UL approval	File number UL	E364788

Mechanical data		
Weight [g]		346.8
Materials	stainless steel (316L/1.4404); PEI; FKM	
Materials (wetted parts)	stainless steel (316L/1.4435); PEEK	
Process connection	threaded connection G 1/2 external thread sealing cone optional:hygienic PEEK gasket according to EHEDG	
Surface characteristics Ra/Rz of the wetted parts	Ra ≤ 0.8 µm	

Remarks		
Remarks	MW = measured value	
Notes	Digital meets analogue: integrating modern IO-Link sensors the analogue way. The EIO104 allows you to realise two analogue signals from intelligent IO-Link sensors with several process values.	
Pack quantity	1 pcs.	

### Electrical connection

Connector: 1 x M12 (EN 61067-2-101); coding: A; Contacts: 4, gold-plated



### Connection

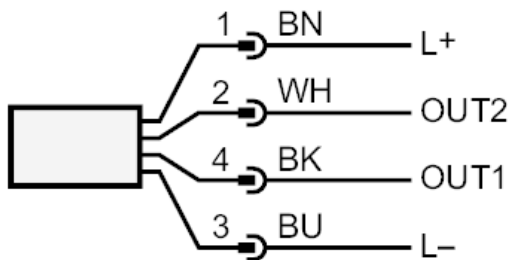

OUT1            IO-Link  
 OUT2            analogue output  
                   colours to DIN EN 60947-5-2  
                   Core colours :

BK =            black  
 BN =            brown  
 BU =            blue  
 WH =            white