



Inductive sensor

IIB3022-ANKG/2M/PUR

phase-out article
Discontinuation date: 03/31/2026

Alternative articles: IIS241
When selecting an alternative article and accessories please note that technical data may differ!

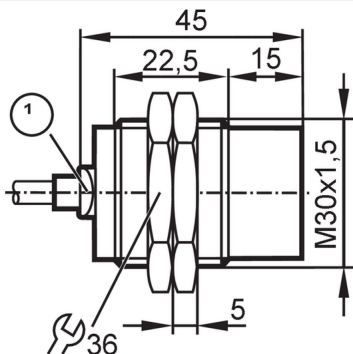

1 LED yellow



Product characteristics

Electrical design	NPN
Output function	normally open
Sensing range [mm]	22
Housing	threaded type
Dimensions [mm]	M30 x 1.5 / L = 45

Application

Special feature	Increased sensing range
Application	Suitable for industrial, mobile, cooling and lubricating applications; Industrial applications / factory automation

Electrical data

Operating voltage [V]	10...30 DC
Current consumption [mA]	< 10
Protection class	III
Reverse polarity protection	yes

Outputs

Electrical design	NPN
Output function	normally open
Max. voltage drop switching output DC [V]	2.5
Permanent current rating of switching output DC [mA]	100
Switching frequency DC [Hz]	100
Short-circuit protection	yes
Overload protection	yes

Detection zone

Sensing range [mm]	22
--------------------	----

IIS245



Inductive sensor

IIB3022-ANKG/2M/PUR

Real sensing range Sr	[mm]	22 ± 10 %
Operating distance	[mm]	0...17.82
Increased sensing range		yes

Accuracy / deviations

Correction factor		steel: 1 / stainless steel: 0.7 / brass: 0.5 / aluminium: 0.4 / copper: 0.3
Hysteresis	[% of Sr]	3...15
Switch point drift	[% of Sr]	-10...10

Operating conditions

Ambient temperature	[°C]	-40...85
Protection		IP 65; IP 66; IP 67; IP 68; IP 69K

Tests / approvals

EMC	EN 61000-4-2 ESD	4 kV CD / 8 kV AD
	EN 61000-4-3 HF radiated	10 V/m
	EN 61000-4-4 Burst	2 kV
	EN 61000-4-6 HF conducted	10 V
	EN 55011	class B
Vibration resistance	EN 60068-2-6 Fc	20 g (10...3000 Hz) / 50 sweep cycles, 1 octave per minute, in 3 axes
Shock resistance	EN 60068-2-27 Ea	100 g 11 ms half-sine; 3 shocks each in every direction of the 3 coordinate axes
Continuous shock resistance	EN 60068-2-27	40 g 6 ms; 4000 shocks each in every direction of the 3 coordinate axes
Fast temperature change	EN 60068-2-14 Na	TA = -40 °C; TB = 85 °C; t1 = 30 min; t2 = < 10 s; 50 cycles
Salt spray test	EN 60068-2-52 Kb	severity level 5 (4 test cycles)
MTTF	[years]	850
Embedded software included		yes
UL approval	Ta	-25...75 °C
	Enclosure type	Type 1
	voltage supply	Limited Voltage/Current
	UL approval no.	A002
	File number UL	E174191

Mechanical data

Weight	[g]	135.7
Housing		threaded type
Mounting		non-flush mountable
Dimensions	[mm]	M30 x 1.5 / L = 45
Thread designation		M30 x 1.5
Materials		housing: brass white bronze coated; sensing face: PBT orange; LED window: PEI; lock nuts: brass white bronze coated

Displays / operating elements

Display	switching status	1 x LED, yellow
---------	------------------	-----------------

Accessories

Items supplied		lock nuts: 2
----------------	--	--------------

Remarks

Pack quantity		1 pcs.
---------------	--	--------

IIS245



Inductive sensor

IIB3022-ANKG/2M/PUR

Electrical connection

Cable: 2 m, PUR, \varnothing 4 mm; burning behaviour to ECE R118 rev. 2; 3 x 0.34 mm²

Connection

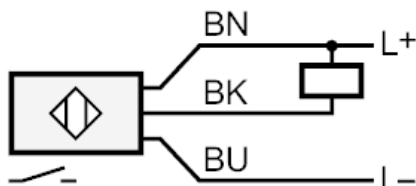

Core colours :
BK = black
BN = brown
BU = blue