

E43378

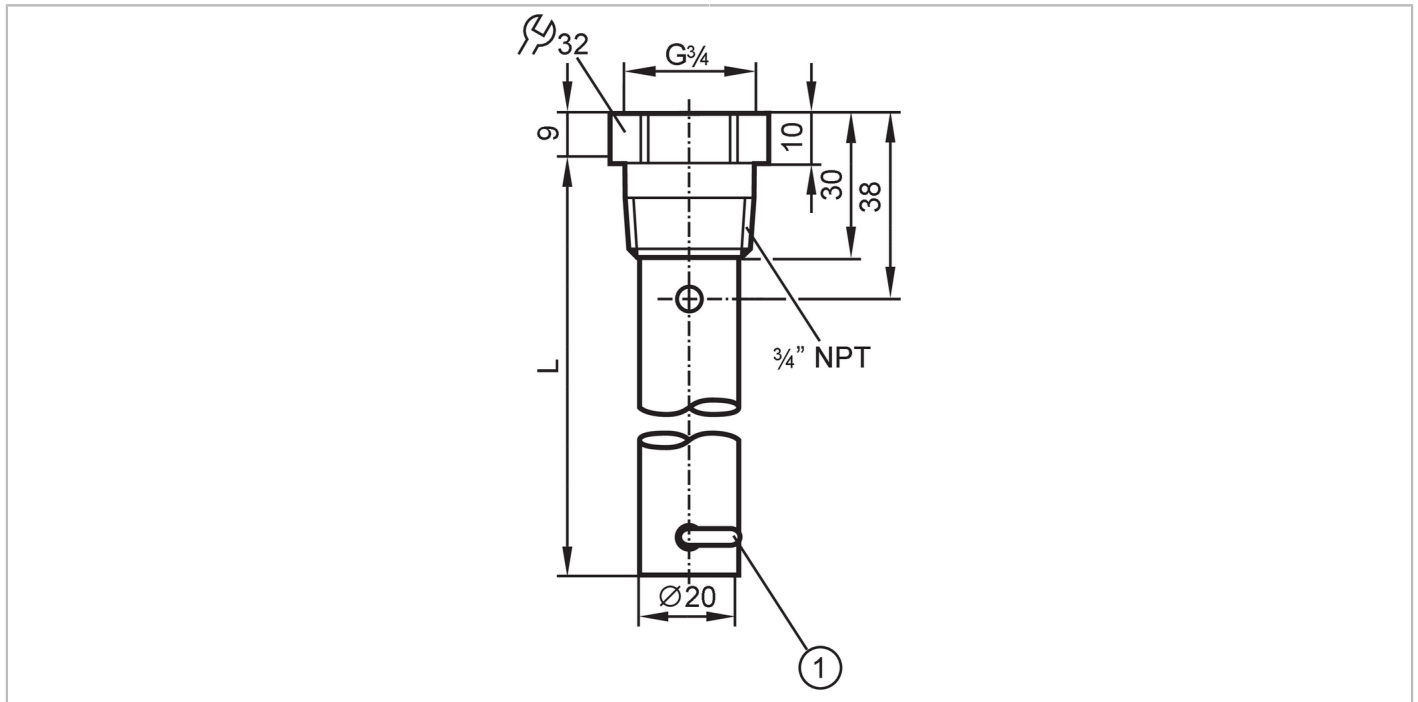

Coaxial pipe for level sensors

LR COAX TUBE NPT L2000



CRN

Application	
Design	for level sensors LR
Medium temperature [°C]	-40...200
Pressure rating	16 bar 1.6 MPa
Vacuum resistance	-1000 mbar -0.1 MPa
MAWP for applications according to CRN [bar]	16
Mechanical data	
Weight [g]	1120
Materials	Coaxial pipe: stainless steel (304/1.4301); fixing bracket: stainless steel (301/1.4310); Centring piece: PPS reinforced fibre
Sensor connection	threaded connection G 3/4 internal thread
Process connection	threaded connection 3/4" NPT external thread
Length L [mm]	2000
Remarks	
Pack quantity	1 pcs.