

E11067

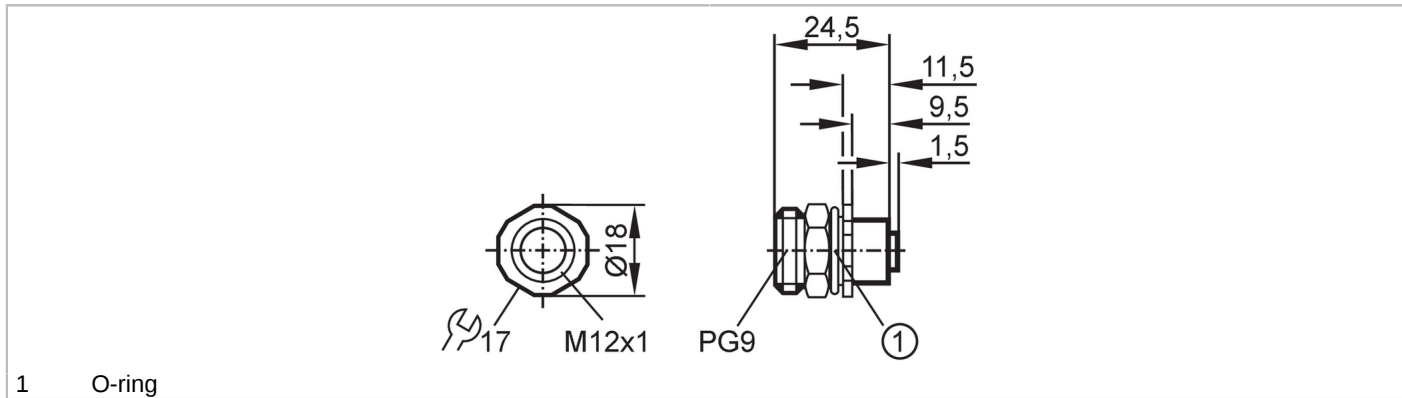

Adapter socket

EDOGH040ZDS00,5E04 (PG9)



1 O-ring



Electrical data

Operating voltage	[V]	< 250 AC/DC
Max. current load total	[A]	4

Operating conditions

Ambient temperature	[°C]	-25...85
Protection		IP 68

Mechanical data

Weight	[g]	22.8
Mounting thread		PG 9
Materials		housing: diecast zinc

Accessories

Items supplied		nut: 1 x PG9
----------------	--	--------------

Remarks

Pack quantity		1 pcs.
---------------	--	--------

Electrical connection

Cable: 0.5 m, PVC; 4 x 0.25 mm²

Electrical connection - socket

Connector: 1 x M12, straight; coding: A; Contacts: 4

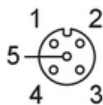

E11067



Adapter socket

EDOGH040ZDS00,5E04 (PG9)

Connection

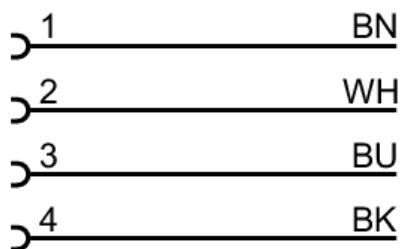

Core colours :
BK = black
BN = brown
BU = blue
WH = white