

ANT515

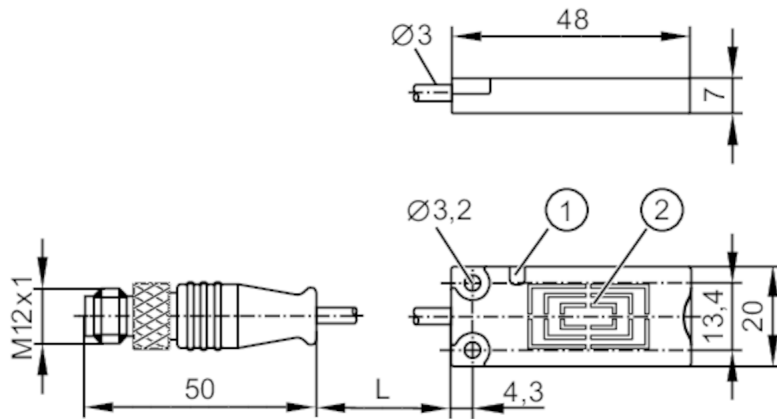

RFID read/write head HF

DTRHF KQRWIDUS03-



- 1 LED
- 2 Sensing face



Application

Application	detection of objects on transport equipment
Radio approval for	USA; Canada; EU/RED; Australia; Japan; China; Taiwan; India; Singapore; Ukraine; Malaysia
Note on radio approval	The list of countries applying the European Radio Equipment Directive 2014/53/EU (RED) can be found under "Downloads".

Electrical data

Operating voltage [V]	19.2...28.8 DC; (supply only via the DTE10x evaluation unit (to EN 60950-1))
Current consumption [mA]	< 50
Protection class	III
Operating frequency [MHz]	13,56
RFID standard	ISO 15693

Detection zone

Distance write/read head front [mm]	120
Distance write/read head side [mm]	100
Distance to the ID tag [mm]	referred to 30 mm coin tag and antenna installed on metal, I-CODE SLI : ≤ 32

Interfaces

Communication interface	DATA / DTE10x
-------------------------	---------------

Operating conditions

Ambient temperature [°C]	-20...60
Storage temperature [°C]	-25...80
Protection	IP 67; IP 69K

Tests / approvals

EMC	DIN EN 61000-6-2
Shock resistance	EN 60068-2-27 50 g 11 ms / 40 g (6 ms, continuous)
Vibration resistance	EN 60068-2-6 20 g 10...2000 Hz
Radio approval	EN 302 291-1 V1.1.1 / EN 302 291-2 V1.1.1

ANT515



RFID read/write head HF

DTRHF KQRWIDUS03-

MTTF	[years]	457.9
------	---------	-------

Mechanical data

Weight	[g]	80
Housing		rectangular
Mounting		non-flush mountable
Dimensions	[mm]	20 x 7 x 48
Materials		PBT; TPE-U; stainless steel

Displays / operating elements

Display	operation	1 x LED, green
	tag communication	1 x LED, yellow

Remarks

Pack quantity	1 pcs.
---------------	--------

Electrical connection

Cable: 1 m, PUR; 3 x 0.14 mm²

Connector: 1 x M12; coding: A



Connection

