

SU2050

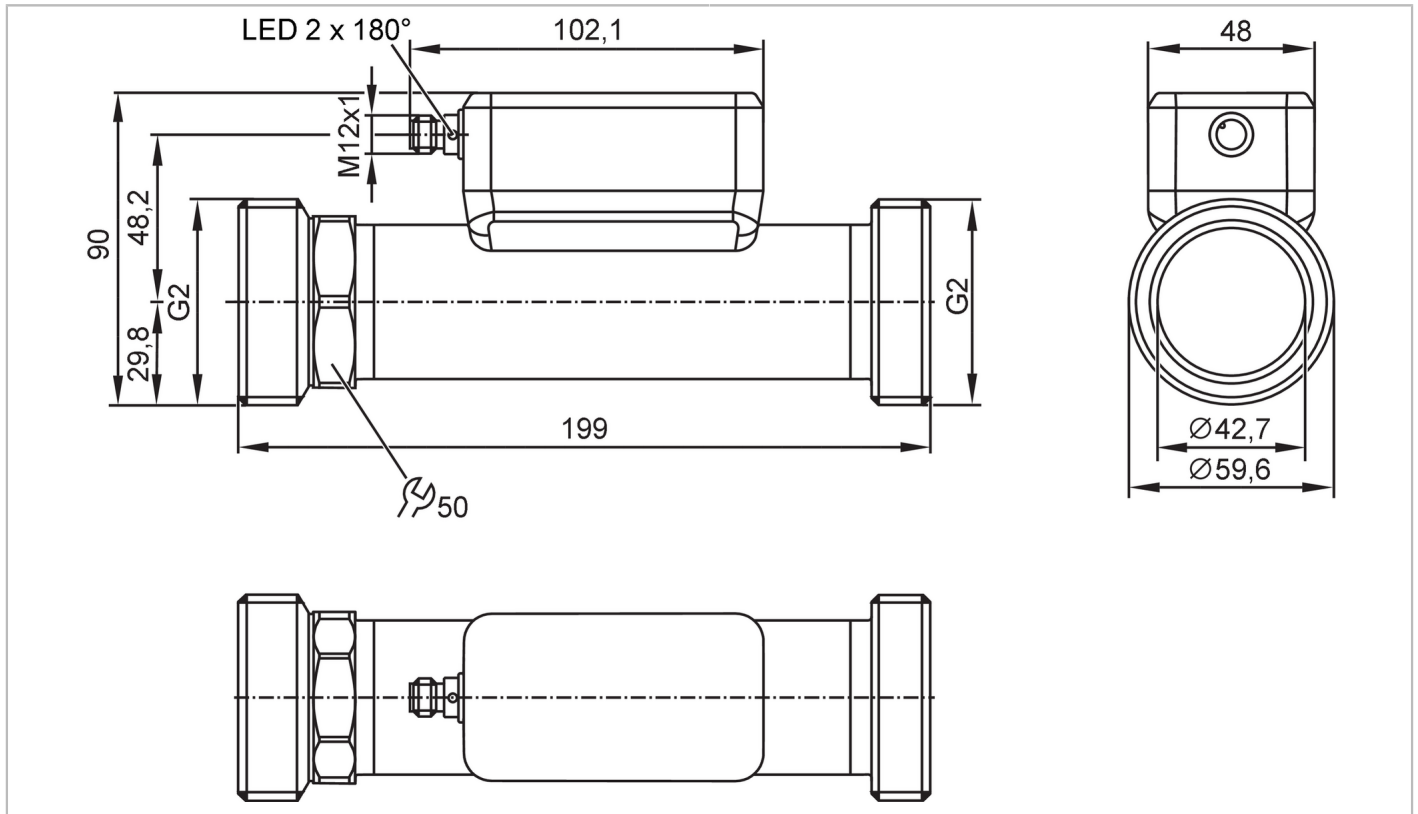

Ultrasonic flow meter

SUR21XJBFRKG/US



ACS KTW/W270 Reg31

Product characteristics

Number of inputs and outputs	Number of digital outputs: 2; Number of analogue outputs: 1			
Measuring range	5...1000 l/min	0.3...60 m³/h	79...15850 gph	1.32...264.18 gpm
Nominal diameter	DN50 (2")			
Process connection	threaded connection G 2 external thread DN50			

Application

Special feature	Gold-plated contacts	
Application	use in mobile and industrial applications	
Media	ultra-pure water; water; hydrous media; glycol solutions; oils (of high and low viscosity); coolants	
Note on media	hydrous media: for media with >10 % additives, the repeatability is the only available value low-viscosity oils with viscosity: 7...40 mm²/s (40 °C) high-viscosity oils with viscosity: 30...68 mm²/s (40 °C)	
Medium temperature	-40...120 °C	-40...248 °F
Min. burst pressure	150 bar	15 MPa
Pressure rating	100 bar	10 MPa
Vacuum resistance [mbar]	-1000	

Electrical data

Operating voltage [V]	8...32 DC; (to SELV/PELV)	
Current consumption [mA]	< 175	
Protection class	III	
Reverse polarity protection	yes	
Power-on delay time [s]	5	

SU2050



Ultrasonic flow meter

SUR21XJBFRKG/US

Measuring principle	ultrasonic			
Inputs / outputs				
Total number of inputs and outputs	2			
Number of inputs and outputs	Number of digital outputs: 2; Number of analogue outputs: 1			
Inputs				
Inputs	OUT2	counter reset		
Outputs				
Total number of outputs	2			
Output signal	OUT1	switching signal; pulse signal; diagnostic signal; totaliser switching signal; frequency signal; IO-Link		
	OUT2	switching signal; pulse signal; diagnostic signal; totaliser switching signal; analogue signal		
Electrical design	PNP/NPN			
Number of digital outputs	2			
Output function	normally open / normally closed; (parameterisable)			
Max. voltage drop switching output DC [V]	2			
Permanent current rating of switching output DC [mA]	100			
Switching frequency DC [Hz]	0...10000			
Number of analogue outputs	1			
Analogue current output [mA]	4...20; (scalable)			
Max. load [Ω]	500			
Analogue voltage output [V]	0...10 / 0.5...4.5; (scalable)			
Min. load resistance [Ω]	2000			
Pulse output	flow rate meter			
Short-circuit protection	yes			
Type of short-circuit protection	pulsed			
Overload protection	yes			
Measuring/setting range				
Measuring range	5...1000 l/min	0.3...60 m ³ /h	79...15850 gph	1.32...264.18 gpm
Resolution	0.1 l/min	0.001 m ³ /h	1 gph	0.01 gpm
Note on factory setting	l/min °C			
Set point SP	10.5...1000 l/min	0.63...60 m ³ /h	166...15850 gph	2.77...264.17 gpm
Reset point rP	5.3...994.8 l/min	0.318...59.688 m ³ /h	84...15768 gph	1.4...262.8 gpm
Analogue start point ASP	-1000...800 l/min	-60...48000 m ³ /h	-15850...12680 gph	-264.17...211.34 gpm
Analogue end point AEP	-800...1000 l/min	-48...60 m ³ /h	-12680...15850 gph	-211.34...264.17 gpm
Low flow cut-off LFC	5...50 l/min	0.3...3 m ³ /h	79...793 gph	1.32...13.21 gpm
Frequency end point, FEP	200.6...1000 l/min	12.037...60 m ³ /h	3180...15850 gph	53...264.17 gpm
Frequency at the end point FRP [Hz]	1...10000			
Volumetric flow quantity monitoring				
Pulse length [s]	0.002...2			

SU2050



Ultrasonic flow meter

SUR21XJBFRKG/US

Pulse value	0.1...99990000 l; 0.03...26414563.515 gal	
Temperature monitoring		
Measuring range	-40...120 °C	-40...248 °F
Resolution	0.1 °C	0.1 °F
Set point SP	-40...119.4 °C	-40...247 °F
Reset point rP	-40...88 °C	-40...190.4 °F
Analogue start point	-8...120 °C	17.6...248 °F
Analogue end point	-40...88 °C	-40...190.4 °F
Frequency start point, FSP	-8...120 °C	17.6...248 °F
Frequency end point, FEP	-40...119.4 °C	-40...247 °F
Frequency at the end point FRP [Hz]	1...10000	

Accuracy / deviations

Flow monitoring		
Accuracy (in the measuring range)	only up to 100 °C; at higher temperatures, only the repeatability is within the specification.	
Accuracy (in the measuring range)	glycol solutions (35%)	±(5,0 % MW + 0,5 % MEW)
	high-viscosity oils with viscosity 46mm ² /s (40°C)	±(5,0 % MW + 0,5 % MEW)
	low-viscosity oils with viscosity 10mm ² /s (40°C)	±(5,0 % MW + 0,5 % MEW)
	water	± (1,0 % MW + 0,5 % MEW)
Repeatability	± 0,2 % MEW	
Temperature monitoring		
Accuracy [K]	± 2,5 (Q > 5 % MEW)	
Temperature coefficient [% of the span / 10 K]	0,2	

Response times

Flow monitoring		
Response time [s]	< 0.25; (dAP = 0, T09)	
Damping process value dAP [s]	0...5	
Temperature monitoring		
Dynamic response T05 / T09 [s]	5,7 / 86	

Software / programming

Diagnostic functions	direction of flow detection; signal quality
----------------------	---

Interfaces

Communication interface	IO-Link	
Transmission type	COM2 (38,4 kBaud)	
IO-Link revision	1.1.3	
SDCI standard	IEC 61131-9: 2013-07	
Profiles	BLOB	Binary Large Object transfer
	Common - I&D	Identification and Diagnosis
Required master port type	A	
Process data analogue	3	
Process data binary	2	
Min. process cycle time [ms]	9.6	

SU2050



Ultrasonic flow meter

SUR21XJBFRKG/US

IO-Link process data (cyclical)	function	bit length
	totaliser	32
	Flow monitoring	32
	Temperature monitoring	32
	status	4
	Output 1	1
	Output 2	1
Supported DeviceIDs	Type of operation	DeviceID
	default	1841

Operating conditions		
Ambient temperature	[°C]	-25...60
Storage temperature	[°C]	-40...80
Protection		IP 67; IP 69K

Tests / approvals		
EMC	DIN 61326-1:2021	
Shock resistance	DIN IEC 68-2-27	20 g (11ms)
Vibration resistance	DIN IEC 68-2-6	20 g (10...2000Hz)
MTTF	[years]	136
UL approval	UL approval no.	I036
	File number UL	E174189
Pressure Equipment Directive	can be used for group 2 fluids; group 1 fluids on request	

Mechanical data		
Weight	[g]	1180
Housing		rectangular
Inlet pipe length		5 x DN
Outlet pipe length		1 x DN
Dimensions	[mm]	199 x 59.6 x 90
Materials	housing: stainless steel (316L/1.4404); connector: PEI, FKM	
Materials (wetted parts)	Pipe section: stainless steel (316L/1.4404); Process connection sealing: NBR reinforced fibre	
Nominal diameter		DN50 (2")
Process connection		threaded connection G 2 external thread DN50
Surface characteristics Ra/Rz of the wetted parts		Ra < 1.25 µm

Displays / operating elements		
Display	operating status	1 x LED, green

Accessories		
Items supplied	Flat seal 2, NBR reinforced fibre package insert	

Remarks		
Remarks	MW = measured value MEW = Final value of the measuring range pulse and totaliser signal are only available for one of the two outputs the accuracy indications are adhered to over the entire application area	
Pack quantity	1 pcs.	

SU2050



Ultrasonic flow meter

SUR21XJBFRKG/US

Electrical connection

Connector: 1 x M12; coding: A; Contacts: 4, gold-plated



Connection

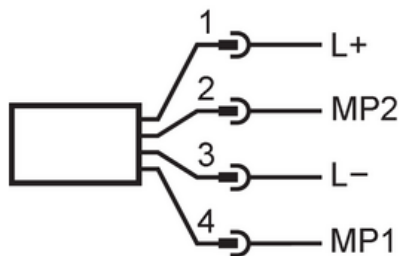

1 (L+)	L+	
2 (OUT2)	MP2	DO, AO, reset
3 (L-)	L-	
4 (OUT1)	MP1	DO, IO-Link

Electrical connection - plug

Diagrams and graphs

Note on pressure loss

