

PI2794



Flush pressure sensor with display

PI-010-REA01-MFRKG/US/ IP

Alternative articles: PI1704

When selecting an alternative article and accessories please note that technical data may differ!

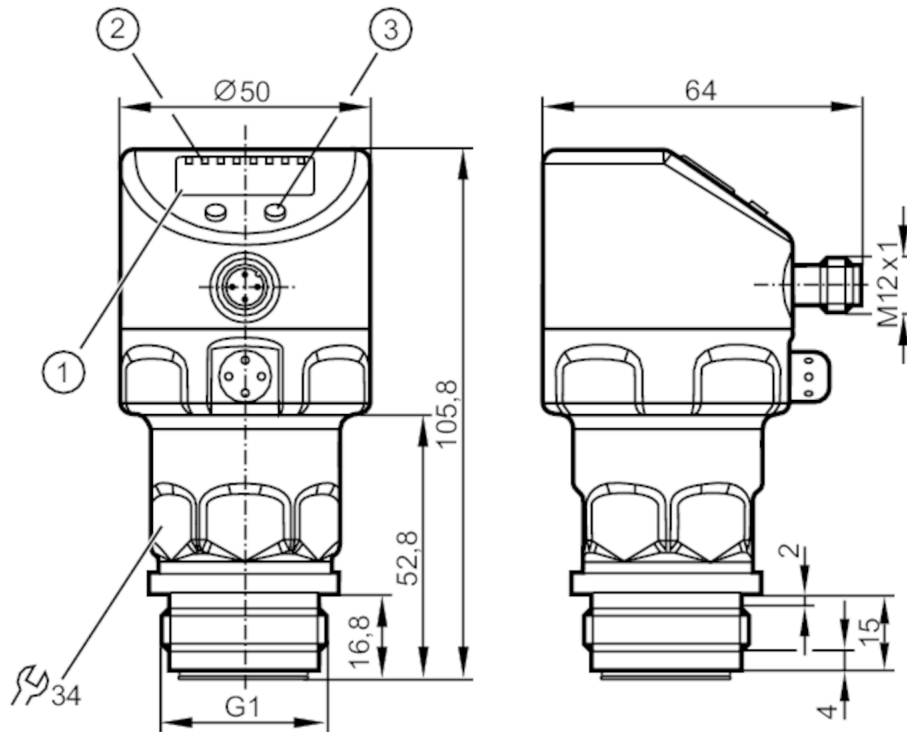

- 1 alphanumeric display 4-digit
- 2 status LEDs
- 3 programming button



ACS



CRN



EC 1935/2004

EHEDG Certified

FCM

FDA

IO-Link

NSF

Reg31

UK CA



Reg31



Product characteristics

Number of inputs and outputs	Number of digital outputs: 2; Number of analogue outputs: 1		
Measuring range	-1...10 bar	-14.5...145 psi	-0.1...1 MPa
Process connection	threaded connection G 1 external thread mit Dichtkontur Aseptoflex Vario		
Note	G1 Gewinde nach ISO 228. Alternativ dichtend über rückwärtige Dichtkontur mit Dichtung in Anlehnung an DIN EN ISO 1179-2.		

Application

Special feature	Gold-plated contacts		
Application	flush mountable for the food and beverage industry		
Media	viscous media and liquids with suspended particles; liquids and gases		
Medium temperature [°C]	-25...125; (145 max. 1h)		
Min. burst pressure	150 bar	2175 psi	15 MPa
Pressure rating	50 bar	725 psi	5 MPa
Vacuum resistance	-1000 mbar	-0.1 MPa	
Type of pressure	relative pressure; vacuum		
No dead space	yes		
MAWP for applications according to CRN	50 bar	725 psi	5 MPa



Flush pressure sensor with display

PI-010-REA01-MFRKG/US/ IP

Electrical data				
Min. insulation resistance	[MΩ]	100; (500 V DC)		
Protection class		III		
Reverse polarity protection		yes		
Integrated watchdog		yes		
2-wire				
Operating voltage	[V]	20...32 DC		
Current consumption	[mA]	3.6...21		
Power-on delay time	[s]	1		
3-wire				
Operating voltage	[V]	18...32 DC		
Current consumption	[mA]	< 45		
Power-on delay time	[s]	0.5		
Inputs / outputs				
Number of inputs and outputs		Number of digital outputs: 2; Number of analogue outputs: 1		
Outputs				
Total number of outputs		2		
Output signal		switching signal; analogue signal; IO-Link; (configurable)		
Electrical design		PNP/NPN		
Number of digital outputs		2		
Output function		normally open / normally closed; (parameterisable)		
Number of analogue outputs		1		
Analogue current output	[mA]	4...20, invertible; (scalable)		
Short-circuit protection		yes		
Type of short-circuit protection		pulsed		
Overload protection		yes		
2-wire				
Max. load	[Ω]	300		
3-wire				
Max. voltage drop switching output DC	[V]	2		
Permanent current rating of switching output DC	[mA]	250		
Switching frequency DC	[Hz]	125		
Max. load	[Ω]	(U _b - 10 V) / 20 mA		
Measuring/setting range				
Measuring range		-1...10 bar	-14.5...145 psi	-0.1...1 MPa
Set point SP		-0.98...10 bar	-14.2...145 psi	-0.098...1 MPa
Reset point rP		-1...9.98 bar	-14.5...144.7 psi	-0.1...0.998 MPa
Analogue start point		-1...7.5 bar	-14.5...108.7 psi	-0.1...0.75 MPa
Analogue end point		1.5...10 bar	21.8...145 psi	0.15...1 MPa
In steps of		0.01 bar	0.1 psi	0.001 MPa

PI2794



Flush pressure sensor with display

PI-010-REA01-MFRKG/US/ IP

Factory setting	SP1 = 2.50 bar	rP1 = 2.30 bar
	SP2 = 7.50 bar	rP2 = 7.30 bar
	ASP = 0.00 bar	AEP = 10.00 bar
	dAP = 0.06 s	dAA = 0.03 s

Accuracy / deviations

Switch point accuracy [% of the span]	< ± 0,2; (Turn down 1:1)
Repeatability [% of the span]	< ± 0,1; (with temperature fluctuations < 10 K; Turn down 1:1)
Characteristics deviation [% of the span]	< ± 0,2; (Turn down 1:1, linearity, incl. hysteresis and repeatability, limit value setting to DIN EN IEC 62828-1)
Linearity deviation [% of the span]	< ± 0,15; (Turn down 1:1)
Hysteresis deviation [% of the span]	< ± 0,15; (Turn down 1:1)
Long-term stability [% of the span]	< ± 0,1; (Turn down 1:1; per year)
Temperature coefficient zero point [% of the span / 10 K]	< ± 0,05; (0...70 °C)
Temperature coefficient span [% of the span / 10 K]	< ± 0,15; (0...70 °C)

Response times

Damping process value dAP [s]	0...30
Damping for the analogue output dAA [s]	0.01...99.99
2-wire	
Step response time analogue output [ms]	45
3-wire	
Min. response time of switching output (dAP) [ms]	3
Step response time analogue output [ms]	7

Interfaces

Communication interface	IO-Link	
Transmission type	COM2 (38,4 kBaud)	
IO-Link revision	1.0	
SIO mode	yes	
Required master port type	A	
Process data analogue	1	
Process data binary	2	
Min. process cycle time [ms]	2.3	
Supported DeviceIDs	Type of operation	DeviceID
	default	157

Operating conditions

Ambient temperature [°C]	-25...80
Storage temperature [°C]	-40...100

PI2794



Flush pressure sensor with display

PI-010-REA01-MFRKG/US/ IP

Protection	IP 67; IP 68; IP 69K
------------	----------------------

Tests / approvals

EMC	DIN EN 61000-6-2	
	DIN EN 61000-6-3	
Shock resistance	DIN EN 60068-2-27	50 g (11 ms)
Vibration resistance	DIN EN 60068-2-6	20 g (10...2000 Hz)
MTTF [years]		160
Note on approval	factory certificate available as download at www.factory-certificate.ifm	

Mechanical data

Weight [g]	351.8
Housing	cylindrical
Dimensions [mm]	Ø 50 / L = 105.8
Materials	stainless steel (316L/1.4404); FKM; PTFE; PBT; PEI; PFA
Materials (wetted parts)	ceramics (99.9 % Al ₂ O ₃); stainless steel (316L/1.4435) surface characteristics: Ra < 0,4 µm / Rz = 4 µm; PTFE
Min. pressure cycles	100 million
Process connection	threaded connection G 1 external thread mit Dichtkontur Aseptoflex Vario

Displays / operating elements

Display	Display unit	LED, green
	switching status	LED, yellow
	function display	alphanumeric display, 4-digit
	measured values	alphanumeric display, 4-digit
Display unit	bar; psi; MPa; % of the span	

Remarks

Pack quantity	1 pcs.
---------------	--------

Electrical connection

Connector: 1 x M12; coding: A; Contacts: 4, gold-plated





Flush pressure sensor with display

PI-010-REA01-MFRKG/US/ IP

Connection

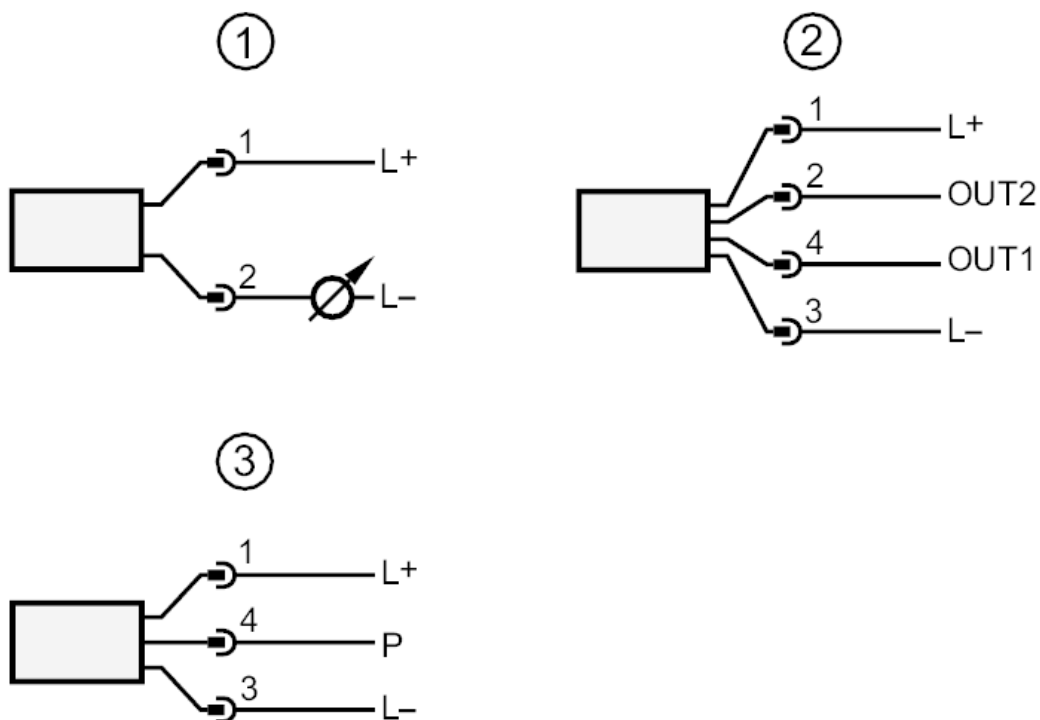

- 1 connection for 2-wire operation
- 2 connection for 3-wire operation :
- OUT1 switching output
- OUT2 switching output
- analogue output
- 3 connection for IO-Link parameter setting (P = communication via IO-Link)