

US0049

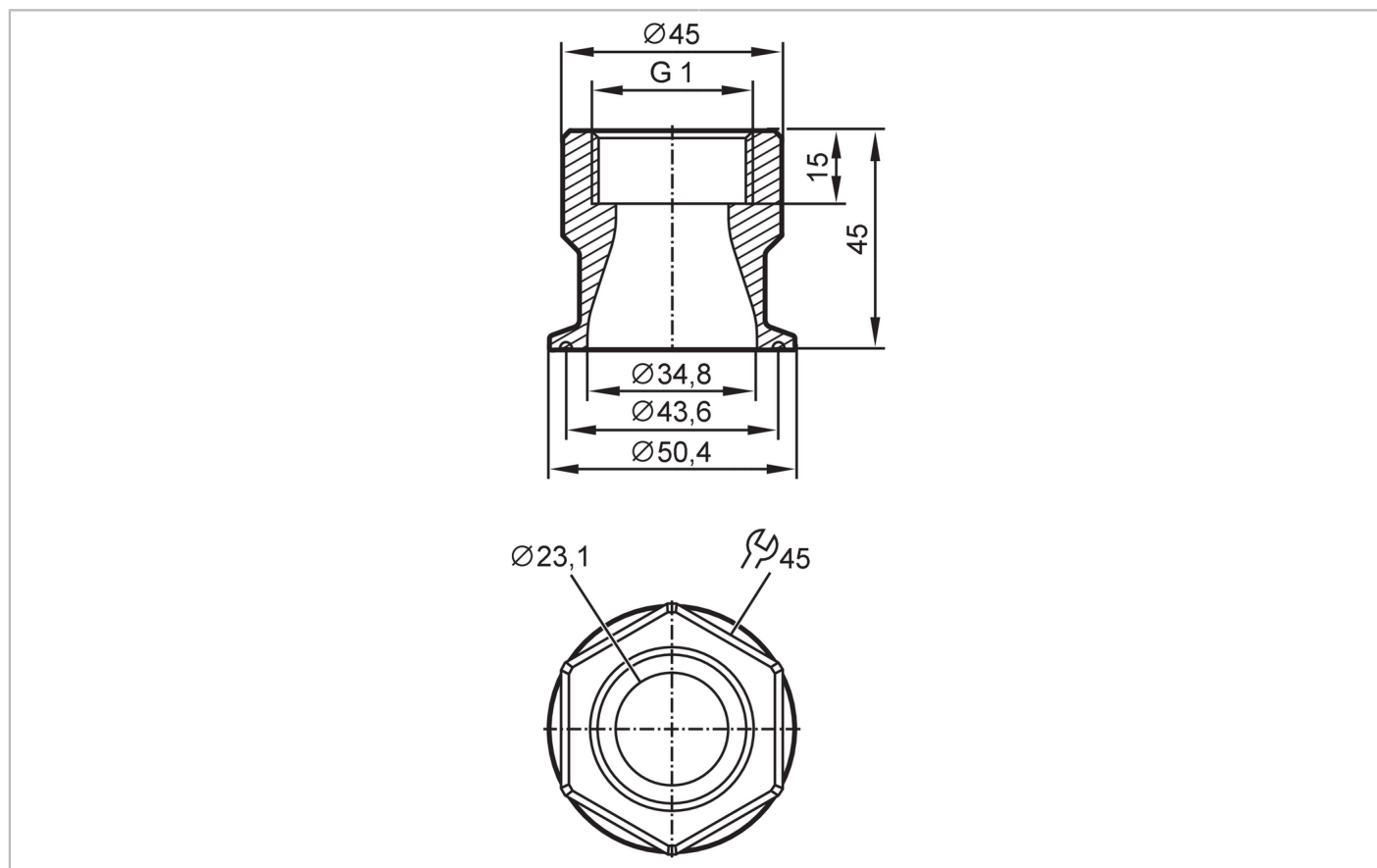

Mounting adapter for inline flow sensors

ADTR, SM, G1, 1.5" TC, SS



Application	
Design	for flow monitors Typ SM8, SU8
Mechanical data	
Weight [g]	610.535
Materials	stainless steel (316L/1.4404)
Sensor connection	G 1
Process connection	Tri-Clamp 1,5"
Accessories	
Items supplied	sealings: 2, Centellen
Remarks	
Pack quantity	2 pcs.