

# E30013

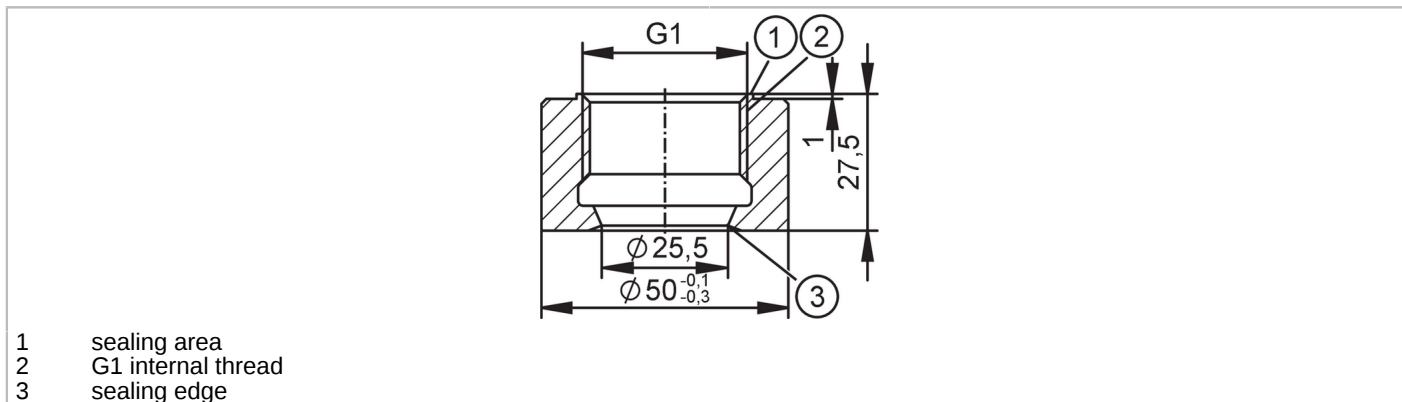

## Welding adapter for process sensors

WELDING ADAPT G1 V4A



CRN EC 1935/2004 FCM FDA Hygienic Cleanable

Application	
Pressure rating	150 bar 15 MPa
Note on pressure rating	for the connection sensor - adapter
MAWP for applications according to CRN [bar]	150
Tests / approvals	
Pressure Equipment Directive	A possible classification to PED depends on the application and has to be carried out by the user / operator.
Safety instructions	The compatibility between medium and product material has to be checked in all applications.
Mechanical data	
Weight [g]	300
Materials (wetted parts)	stainless steel (316L/1.4404) surface characteristics: Ra < 0,4 µm / Rz = 4 µm
Sensor connection	G 1 sealing cone
Process connection	welding adapter Ø 50 mm
Remarks	
Pack quantity	1 pcs.