

## Aangeboden kabel met stekker

Cable/Connecting/14p/2m

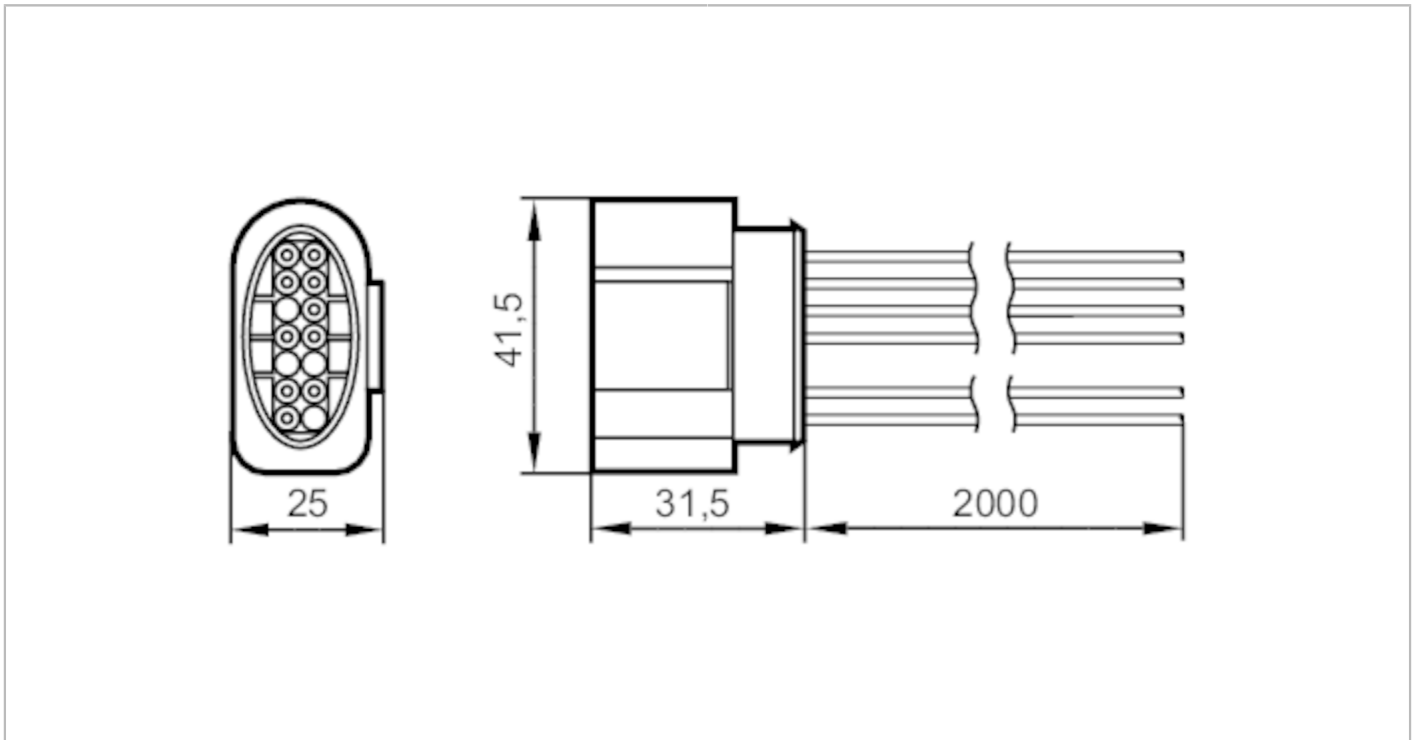

CE

### Elektrische eigenschappen

Voedingsspanning [V] 8...32 DC

### Omgevingsvariabelen

Opslagtemperatuur [°C] -40...80

Beschermklasse IP 67

### Mechanische eigenschappen

Gewicht [g] 147,3

### Opmerkingen

Verpakkingseenheid 1 stuk

### Elektrische aansluiting

Kabel: 2,0 m, PUR, zwart; 10 x 0,5 mm<sup>2</sup>

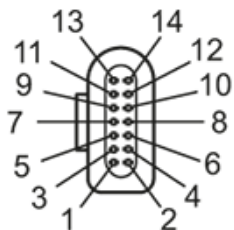

# EC3146



## Aangegoten kabel met stekker

Cable/Connecting/14p/2m

### Aansluiting

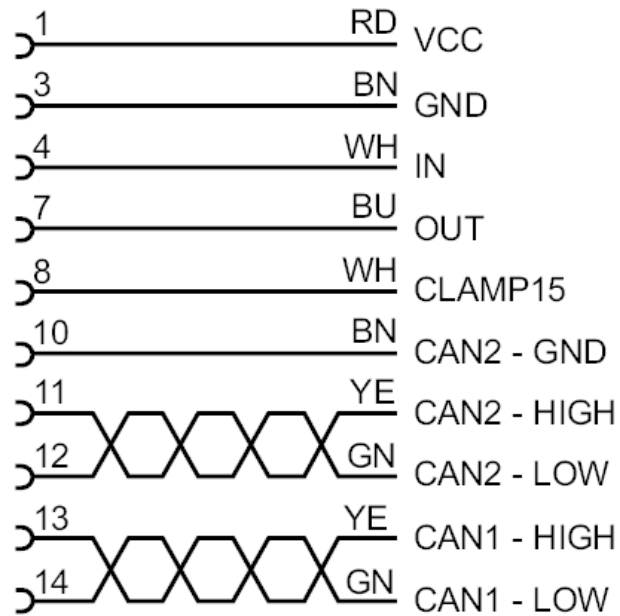

BN =	bruin
BU =	blauw
GN =	groen
RD =	rood
WH =	wit
YE =	geel