



Operating instructions
Electronic level and
temperature sensor

UK

LT80xx

80264357 / 00 05 / 2019

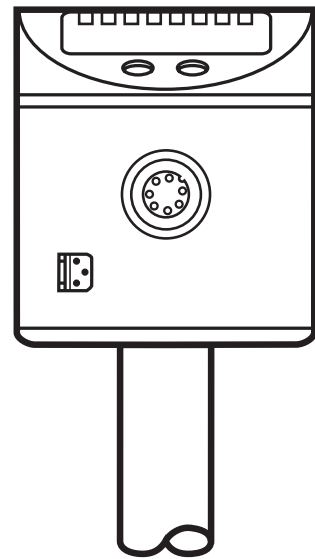

Contents



1	Preliminary note.....	4
1.1	Symbols used	4
2	Safety instructions	5
3	Functions and features	6
3.1	Application area	6
3.2	Restriction of the application area	6
4	Getting started	6
4.1	Example configuration 1	7
4.2	Example configuration 2	8
5	Function	9
5.1	Measuring principle level	9
5.2	Measuring principle temperature	10
5.3	Operating principle / features of the unit.....	10
5.3.1	Operating modes	11
5.3.2	Notes on the integrated overflow prevention	12
5.3.3	Display and switching functions.....	12
5.3.4	Offset for indicating the real level in the tank.....	14
5.3.5	Defined state in case of a fault	14
5.3.6	Extreme value memory.....	14
5.3.7	IO-Link	14
6	Mounting	15
6.1	Notes on installation instructions for operation with overflow prevention ...	16
6.2	Installation instructions for operation without overflow prevention	17
6.2.1	Installation in the inactive zone.....	17
6.2.2	Installation in the active zone of the probe	18
6.3	Other installation notes	19
6.3.1	Marking of the installation height	19
7	Electrical connection.....	20
8	Operating and display elements	22
9	Menu.....	23
9.1	Menu.....	23

10	Parameter setting	24
10.1	Parameter setting in general	24
10.2	Basic settings	25
10.2.1	Assign process values to the outputs [SEL3] / [SEL4].....	25
10.2.2	Assign process value to the display [SELD].....	25
10.2.3	Define unit of measurement for level [uni.L]	26
10.2.4	Set the unit of measurement for the temperature [uni.T].....	26
10.2.5	Set the offset [OFS]	26
10.2.6	Set the medium [MEdI]	26
10.2.7	Set the overflow prevention [OP].....	27
10.2.8	Adjust the overflow prevention [cOP].....	28
10.3	Setting of output signals	29
10.3.1	Set output function [oux] für OUT1...OUT4	29
10.3.2	Define the switching limits [SPx] / [rPx] (hysteresis function).....	29
10.3.3	Define switching limits [FHx] / [FLx] (window function).....	30
10.3.4	Set set delay [dSx]	30
10.3.5	Set reset delay [drx]	30
10.3.6	Define switching logic [P-n]	30
10.3.7	Define response of the outputs in case of a fault [FOUx]	30
10.3.8	Configure display [diS].....	31
10.3.9	Reset all parameters to factory settings [rES]	31
11	Notes on parameter setting via IO-Link	31
12	Operation.....	32
12.1	Operating indicators	32
12.2	Read the set parameters	32
12.3	Read / reset extreme value memory temperature	33
12.4	Fast selection level / temperature.....	33
12.5	Error indications.....	33
12.6	Output response in different operating states.....	34
13	Technical data.....	34
13.1	Setting values [OFS].....	34
13.2	Setting ranges switching limits for level	34
13.3	Setting ranges switching limits for temperature.....	35
13.4	Setting values [OP]	35
13.5	Calculation aids [OP]	36
13.5.1	Definition "from the cover"	36

13.5.2 Definition "from the bottom"	36
14 Maintenance / cleaning / change of medium	37
14.1 Maintenance information for operation without overflow prevention	37
15 Factory setting	38
16 Applications.....	39
16.1 Storage tank	39
16.2 Pumping station.....	40

1 Preliminary note

1.1 Symbols used

- ▶ Instructions
- > Reaction, result
- [...] Designation of keys, buttons or indications
- Cross-reference
-  Important note
Non-compliance may result in malfunction or interference.
-  Information
Supplementary note.

	<p>CAUTION!</p> <p>Warning of personal injury Slight reversible injuries may result.</p>
--	---

2 Safety instructions

- The device described is a subcomponent for integration into a system.
 - The manufacturer of the system is responsible for the safety of the system.
 - The system manufacturer undertakes to perform a risk assessment and to create a documentation in accordance with legal and normative requirements to be provided to the operator and user of the system. This documentation must contain all necessary information and safety instructions for the operator, the user and, if applicable, for any service personnel authorised by the manufacturer of the system.
- Read this document before setting up the product and keep it during the entire service life.
- The product must be suitable for the corresponding applications and environmental conditions without any restrictions.
- Only use the product for its intended purpose (→ Functions and features).
- Only use the product for permissible media (→ Technical data).
- If the operating instructions or the technical data are not adhered to, personal injury and/or damage to property may occur.
- The manufacturer assumes no liability or warranty for any consequences caused by tampering with the product or incorrect use by the operator.
- Installation, electrical connection, set-up, operation and maintenance of the unit must be carried out by qualified personnel authorised by the machine operator.
- Protect units and cables against damage.
- The unit complies with the standard EN 61000-6-4. The unit may cause radio interference in domestic areas. If interference occurs, the user must take appropriate actions.

3 Functions and features

3.1 Application area

The unit was especially designed to meet the requirements of machine tool building. It is especially suitable for monitoring coolant emulsions (also dirty) as well as cutting and hydraulic oils.

The unit monitors 2 process values: level and temperature.

3.2 Restriction of the application area

- The unit is not suitable for
 - acids and alkalis
 - hygienic and electroplating applications
 - highly conductive and adhesive media (e.g. glue, shampoo)
 - granulates, bulk material
 - use in grinders (increased risk of formation of deposits).
- It is possible that foam of good conductivity is detected as level.
 - ▶ Test proper functioning in an application test.
- For water and hydrous media with temperatures $> 35\text{ °C}$, install the unit in a climatic tube (→ Accessories).
- For automatic medium detection (→ 5.3.1):
For media which are very inhomogeneous, separate from each other and thus forming separation layers (e.g. oil layer on water), the following applies:
 - ▶ Test proper functioning in an application test.

4 Getting started

For fast set-up, the example configurations described in the following can be used for most applications. The indicated minimum distances apply exclusively to each separately described case.

4.1 Example configuration 1

Unit	LT8022 (probe length L= 264 mm)
Medium to be detected	Mineral oil
Operating mode	Manual media selection with overflow prevention (Factory setting → 5.3.1)
Installation environment	Metal tank, installation to Fig. 4-1

- ▶ Install unit.
- ▶ Observe the distances (x), (u) and (c):

x:	min. 4.0 cm
u:	min. 1.0 cm
c:	max. 14.0 cm

- ▶ Ground sensor and tank via an electrical connection (→ 7).
- ▶ Observe the parameter setting sequence:
 - [MEdl] = [OIL.2] (→ 10.2.6)
 - [OFS] = (u); e.g. (u) = 2.0 cm (→ 5.3.4)
 - [OP]: Set the overflow prevention OP at a distance (y) greater than 4.5 cm below the mounting element.



For distances (y) smaller than 4.5 cm there may be malfunctioning and error messages during the adjustment process [cOP].



Step increment and setting range: (→ 13.4).
Calculation aids for [OP]: (→ 13.5).

- ▶ Adjustment of the overflow prevention OP to [cOP] (→ 10.2.8).
- > The unit is ready for operation.
- ▶ Make further settings if necessary.
- ▶ Check whether the unit operates correctly.

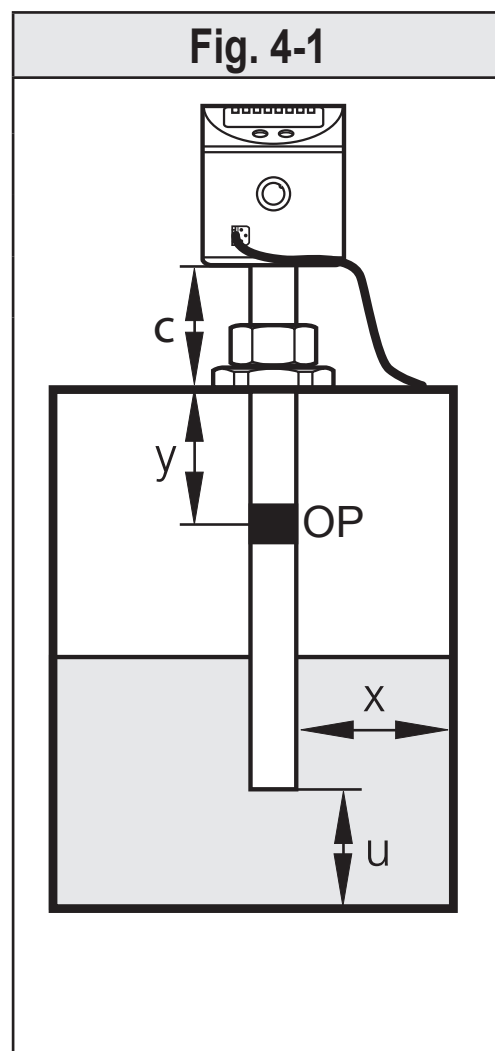

UK

4.2 Example configuration 2

Unit	LT8023 (probe length L= 472 mm)
Medium to be detected	Coolant emulsion
Operating mode	Automatic medium detection (→ 5.3.1)
Installation environment	Metal tank, installation to Fig. 4-2.

- ▶ Install unit.
- ▶ Observe the distances (x), (u) and (c):

x:	min. 4.0 cm
u:	min. 1.0 cm
c:	max. 23.0 cm

- ▶ Ground sensor and tank via an electrical connection (→ 7).
- ▶ Observe the maximum permitted level (b).



A distance (a2) greater than 5.0 cm must be observed between maximum level (b) and mounting element.

- ▶ Observe the parameter setting sequence:
 - [MEdl] = [Auto] (→ 5.3.4)
 - [OFS] = (u); e.g. (u) = 1.0 cm (→ 5.3.4)
 - [SP1] = Set the switch point at a distance (a2)

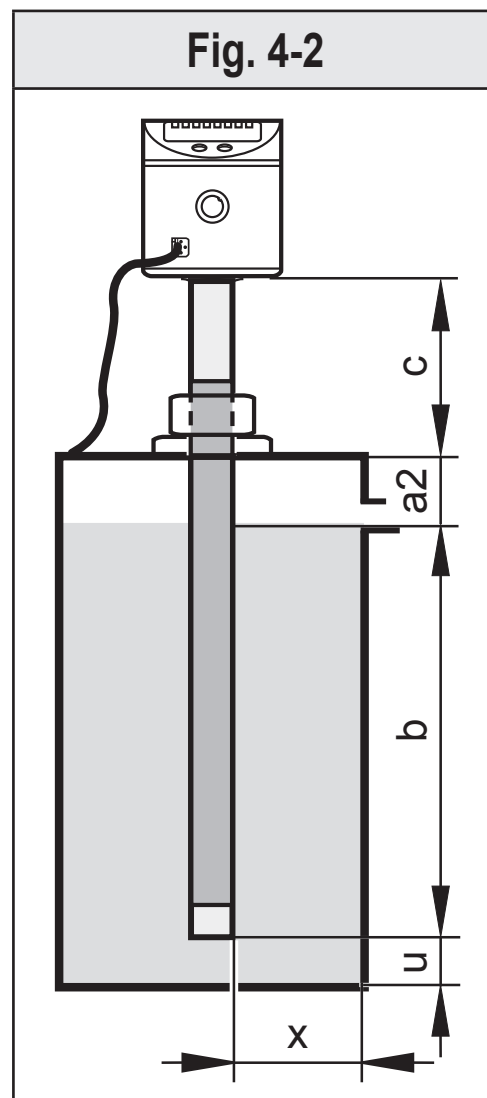

Switch points [SP3] and [SP4] can be used to control the medium temperature and to set limit values for early warning / alarm.

- ▶ **Unit must be reinitialised:**
- ▶ Switch the operating voltage off and on again.
- > The unit is ready for operation.
- ▶ Make further settings if necessary.
- ▶ Check whether the unit operates correctly.

5 Function

5.1 Measuring principle level

The sensor determines the level according to the capacitive measuring principle:

- An electrical field [E] is generated and influenced by the medium to be detected. This change to the field causes a measurement signal that is electronically evaluated.
- The dielectric constant of a medium is important for its detection. Media with a high dielectric constant (e.g. water) generate a strong measurement signal, media with a low dielectric constant (e.g. oils) a correspondingly lower signal.
- The active measurement zone of the sensor probe is composed of 16 capacitive measuring segments. They generate measurement signals depending on the degree of coverage.

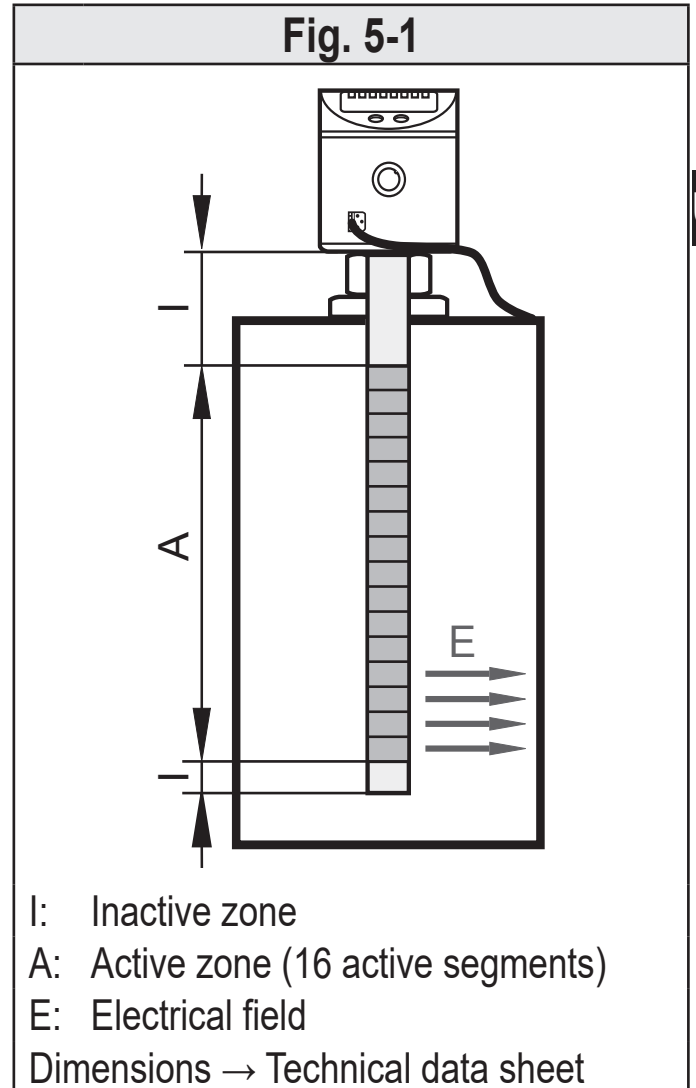

5.2 Measuring principle temperature

The temperature is detected by a Pt element at the lower end of the probe and electronically evaluated.

- Media without water content (e.g. oils) are directly (in contact with the medium) detected.
- Hydrous media can also be directly detected up to temperatures of 35 °C.



For temperatures > 35 °C a climatic tube has to be installed for use in hydrous media (→ 3.2). That means that temperature detection is indirect (not in contact with the medium).

If a climatic tube is used, considerably increased response times have to be expected.

5.3 Operating principle / features of the unit

The unit can be installed in tanks of different sizes. Observe the notes on installation.

4 outputs are available. They can be set separately.

OUT1	Switching signal for level limit value / IO-Link
OUT2	Switching signal for level limit value
OUT3	Switching signal for level limit value
OUT4	or Switching signal for temperature limit

To adapt to the present application select the required operating mode.

5.3.1 Operating modes

1. Manual media selection with overflow prevention (factory setting)

Recommended. Highest operational reliability.

The medium to be detected is set manually [MEdI]. In addition, an integrated, independently functioning overflow prevention is available.

2. Manual media selection without overflow prevention

Medium operational reliability.

The medium to be detected is set manually as described under 1. However, the overflow prevention is deactivated. For this reason, no adjustment is required.

3. Automatic medium detection

Lowest operational reliability.

Each time the operating voltage is switched on, the unit adjusts itself to the medium and the installation environment.



For automatic media detection, **no** overflow prevention is available.

Automatic media detection can only function properly under certain conditions (e.g. compliance with special mounting specifications, restrictions for operation and maintenance).

5.3.2 Notes on the integrated overflow prevention

With the parameter [OP] (OP = overflow prevention), one of the upper measuring segments is defined as integrated overflow prevention.

- If the overflow prevention OP is activated, an adjustment to the installation situation has to be made [cOP]. Otherwise, the unit is not ready for operation; [≡≡≡≡] is displayed until readiness (→ 12.1).
- The overflow prevention OP can be deactivated ([OP] = [OFF]).



Deactivating the overflow prevention OP can impair the operational reliability. For optimum operation and maximum operational reliability, we therefore recommend to **not** deactivate the overflow prevention OP.

- The overflow prevention OP is the maximum limit of the measuring range. The switch points [SPx] / [FHx] are always below [OP].
- The overflow prevention is **not** assigned to a separate output. It offers additional protection and only switches if, as the level rises, the switching output has not switched even though the corresponding switch point has been exceeded (e.g. due to application-related malfunctions).
- Typically the overflow prevention OP reacts when the selected measuring segment has been reached (a few mm before the set OP value).
- The overflow prevention OP replies immediately and without delay. The set delay times (e.g. of a switch point directly below) have no effect on the overflow prevention OP.
- The response of the overflow prevention is only indicated on the display ([Full] and indication of the current level change every second).

5.3.3 Display and switching functions

The device displays the current level / the current temperature, optionally in cm / inches or °C / °F. The display unit is defined by programming. The set unit of measurement and the switching status of the switching outputs are indicated by LEDs.

The displayed process value (level / temperature) can be changed temporarily in the operating mode.

► Briefly press [Set].

> Display of the other unit of measurement for 30 s; the respective LED is lit.

The unit signals via four switching outputs that set limits have been exceeded or that the level is below the limit.

- Outputs OUT1 / OUT2 are assigned to the process value *level*.
- Outputs OUT3 / OUT4 are freely programmable:

Parameter [SEL3] / [SEL4] assigns the process value, level / temperature, to the outputs OUT3 / OUT4 (→ 10.2.1).

Selectable switching functions:

- Hysteresis function / normally open (Fig. 5-2): $[oux] = [Hno]$.
- Hysteresis function / normally closed (Fig. 5-2): $[oux] = [Hnc]$.

 First the set point [SPx] is set, then the reset point [rPx] with the requested difference.

 The hysteresis for the overflow prevention OP is fixed.

- Window function / normally open (Fig. 5-3): $[oux] = [Fno]$.
- Window function / normally closed (Fig. 5-3): $[oux] = [Fnc]$.

 The width of the window can be set by means of the difference between [FHx] and [FLx]. [FHx] = upper value, [FLx] = lower value.

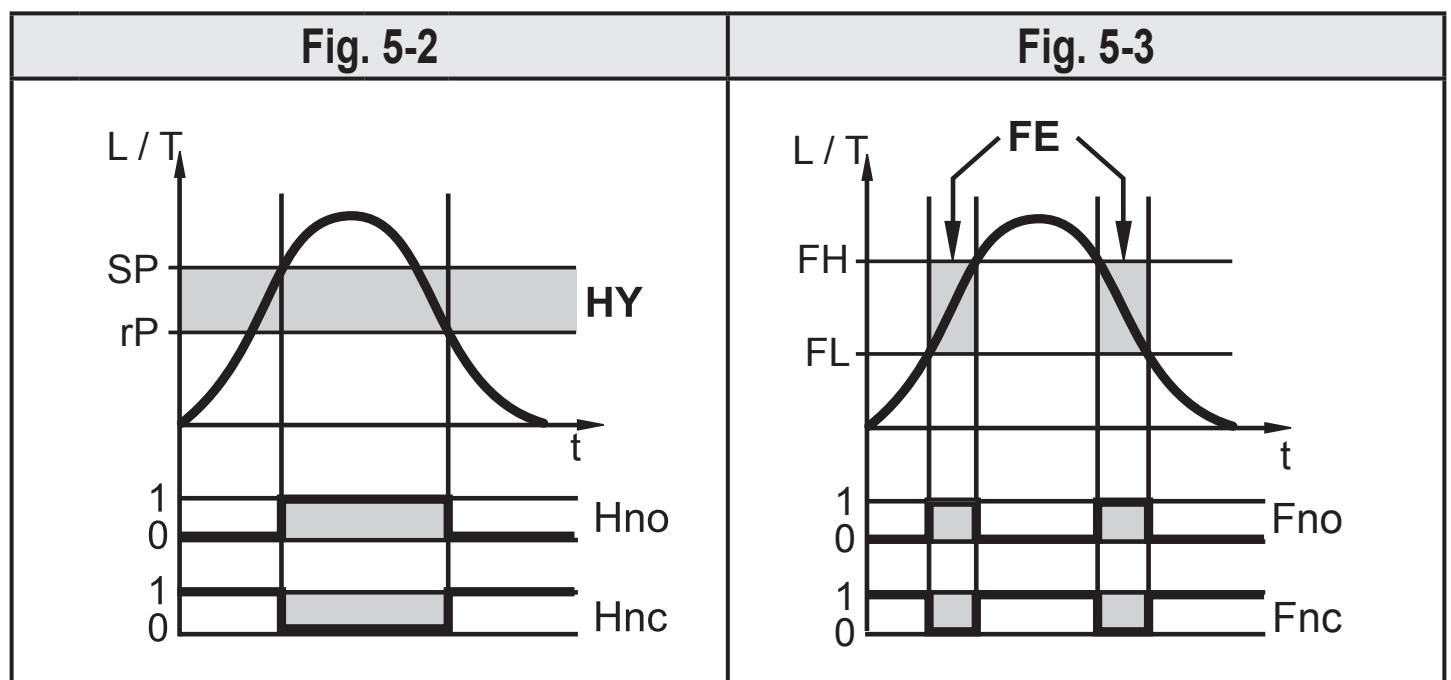

L: Level HY: Hysteresis
T: Temperature FE: Window

5.3.4 Offset for indicating the real level in the tank

The distance between tank bottom and lower edge of the probe can be entered as offset value [OFS]. So display and switch points refer to the actual level (point of reference = tank bottom)



For [OFS] = [0]: The reference point is the lower edge of the measuring probe.



The set offset only refers to the display on the unit. It has no effect on the process value transmitted via IO-Link. The OFS parameter, however, is correctly transmitted via IO-Link and can therefore be taken into consideration.

More information → 5.3.7.

5.3.5 Defined state in case of a fault

In case of a fault a state can be defined for each output. If a fault is detected or if the signal quality is below a minimum value, the outputs pass into a defined state. For this case the response of the outputs can be set via the parameters [FOU1]... [FOU4] [FOU4] (→ 5.3.5)

5.3.6 Extreme value memory

The minimum and maximum values of the temperatures occurred since the last memory reset can be retrieved via the menu items [Lo.T] and [Hi.T].

5.3.7 IO-Link

This unit has an IO-Link communication interface which enables direct access to process and diagnostic data.

In addition it is possible to set the parameters of the unit during operation.

Operation of the unit via IO-Link interface requires an IO-Link capable module (IO-Link master).

With a PC, suitable IO-Link software and an IO-Link adapter cable communication is possible when the system is not in operation.

The IODDs necessary for the configuration of the unit, detailed information about process data structure, diagnostic information, parameter addresses and the necessary information about the required IO-Link hardware and software can be found at www.ifm.com.

6 Mounting



CAUTION!

The surface of the unit may get hot if the switching outputs are operated at maximum load.

- > Risk of burns
- ▶ Do not touch the unit
- ▶ Protect the housing against contact with flammable substances and unintentional contact.

UK

Fig. 6-1

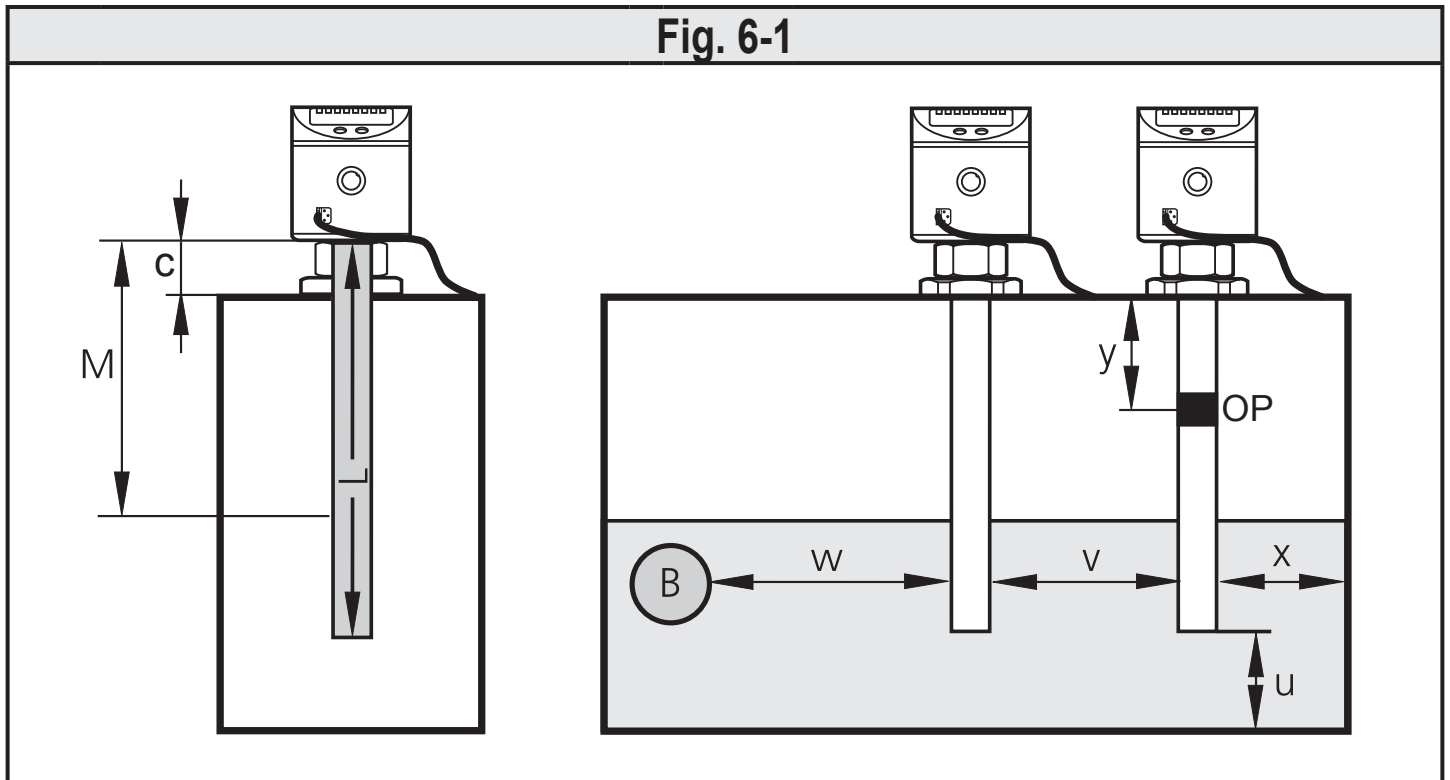

L: Probe length
 M: Zone for mounting elements
 c: Maximum outside length

u ... y: Minimum distances
 OP: Overflow prevention
 B: Metal object inside the tank

Table 6-1

	LT8022		LT8023		LT8024	
	[cm]	[inch]	[cm]	[inch]	[cm]	[inch]
L (rod length)	26.4	10.4	47.2	18.6	72.8	28.7
M (mounting zone)	14.0	5.5	23.0	9.1	36.0	14.2
c (max. outside length)*						

* Applies to installation as shown (wall thickness of the tank lid was neglected; mounting element does not protrude inside the tank).
 Otherwise note mounting zone M.

6.1 Notes on installation instructions for operation with overflow prevention

[MEdl] = [CLW..] or [OIL..];

[OP] = [value ...] (overflow prevention OP activated)



It is permitted to fix the mounting elements within the mounting zone (M) (Fig. 6-1).

- ▶ Observe the maximum permitted outside length (c) according to Table 6-1.
- ▶ Observe the minimum distances according to Fig. 6-1 and Table 6-2.
- ▶ Observe the notes on the integrated overflow prevention OP.



The overflow prevention (OP) must:

1. be below the mounting element
2. be set at a minimum distance (y) to it.

The minimum distance is measured between upper edge mounting element and OP value.

Table 6-2

	MEdl = CLW.1		MEdl = CLW.2, OIL.1		MEdl = OIL.2	
	[cm]	[inch]	[cm]	[inch]	[cm]	[inch]
x	2.0	0.8	3.0	1.2	4.0	1.6
u	1.0	0.4	1.0	0.4	1.0	0.4
y (LT8022)	2.5	1.0	3.5	1.4	4.5	1.8
y (LT8023)	4.5	1.8	5.5	2.2	6.5	2.6
y (LT8024)	6.0	2.4	7.0	2.8	8.0	3.2
v	4.5	1.8	4.5	1.8	4.5	1.8
w	4.0	1.6	5.0	2.0	6.0	2.4



Calculation aids for [OP]: → 13.5

6.2 Installation instructions for operation without overflow prevention

[MEdl] = [Auto] or [OP] = [OFF] (overflow prevention OP deactivated)

6.2.1 Installation in the inactive zone



Between the maximum level (b1) and the inactive zone (I1), minimum distance (a1) must be adhered to (see Fig. 6-2 and Table 6-3).

- ▶ Fix the unit using mounting elements in the inactive zone (I1). The outside length (c) must not exceed (I1) (Table 6-3).
- ▶ Ensure that the maximum level (b1) is not exceeded after completed installation (Table 6-3).
- ▶ Observe further minimum distances according to Table 6-4.

I1 / I2: Inactive zones

A: Active zone

a1: Minimum distance between the inactive zone (I1) and the maximum level (b1)

b1: Max. level from the lower edge of the sensor (without offset)

c: outside length

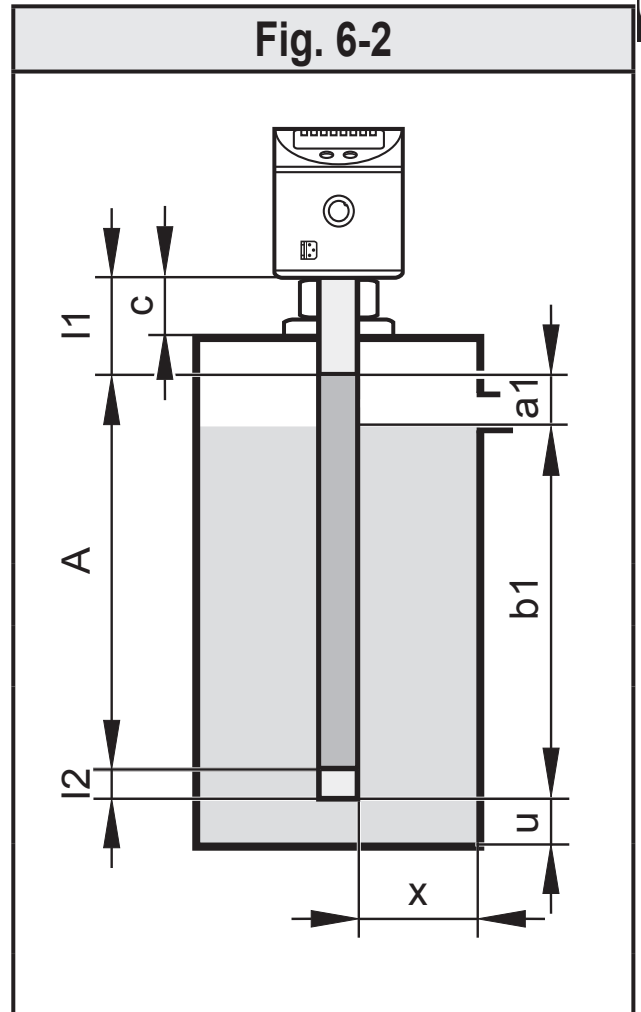

Table 6-3

	LT8022		LT8023		LT8024	
	[cm]	[inch]	[cm]	[inch]	[cm]	[inch]
I1	5.3	2.1	6.0	2.4	10.4	4.1
A	19.5	7.7	39.0	15.4	58.5	23.0
a1	1.0	0.4	1.5	0.6	2.5	1
b1	20.0	7.9	39.5	15.6	59.5	23.4

6.2.2 Installation in the active zone of the probe



The minimum distance (a2) must be observed between the maximum level (b2) and the mounting element (a2) (Fig. 6.3 and Table 6-4).

- ▶ Fix mounting elements in the mounting zone (M) (fig. 6-1). Adhere to maximum permitted outside length (c) (see 6-1).
- ▶ Ensure that the maximum level (b2) is not exceeded after completed installation:

$$(b2) = (L) - (c) - (a2) \quad (\text{without offset})$$

- ▶ Observe further minimum distances according to Table 6-4.



- c: outside length
(max. outside length Table 6-1)
- a2: Minimum distance between the mounting element and the maximum level (b).
- b2: Max. level from the lower edge of the sensor.

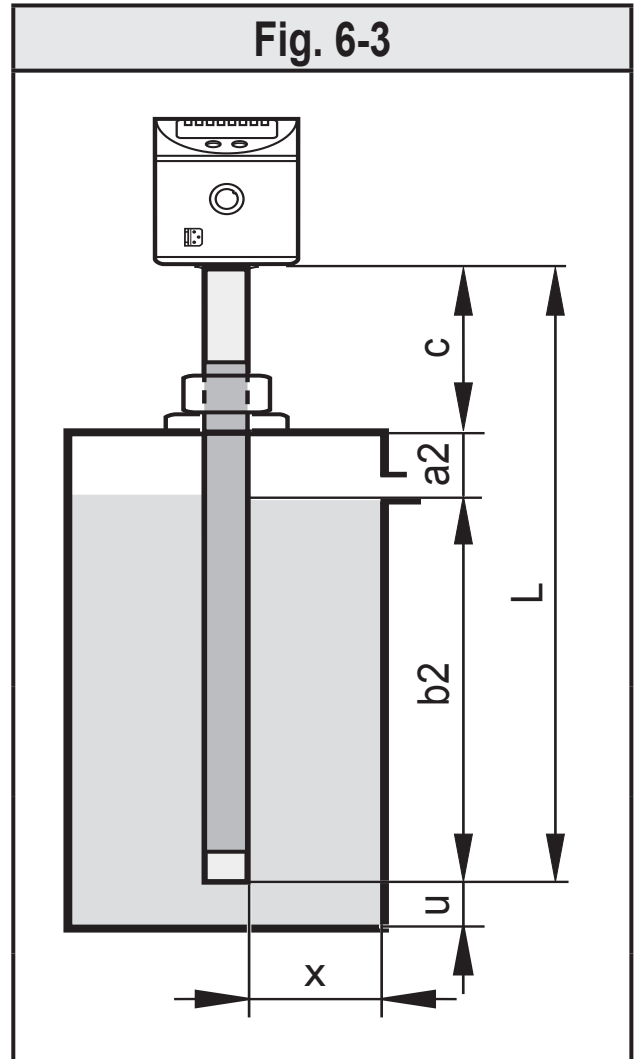

Table 6-4

	MEdl = CLW.1		MEdl = CLW.2, OIL.1		MEdl = OIL.2 / Auto	
	[cm]	[inch]	[cm]	[inch]	[cm]	[inch]
x	2.0	0.8	3.0	1.2	4.0	1.6
u	1.0	0.4	1.0	0.4	1.0	0.4
a2 (LT8022)	2.0	0.8	2.5	1.0	3.0	1.2
a2 (LT8023)	4.0	1.6	4.5	1.8	5.0	2.0
a2 (LT8024)	6.0	2.4	7.0	2.8	8.0	3.2
v *)	4.5	1.8	4.5	1.8	4.5	1.8
w *)	4.0	1.6	5.0	2.0	6.0	2.4

*) → Fig. 6-1.



In case of automatic medium detection [MEdI] = [Auto] or deactivated overflow prevention [OP] = [OFF], the sensor reinitialises itself each time it is switched on and makes adjustments to the medium and the installation environment. The active zone / measuring range must **not** be completely covered by the medium. The indicated minimum distances ensure this. Too short a distance may lead to maladjustments and malfunctions.

6.3 Other installation notes

- For mounting in plastic pipes/plastic tanks, the inside (pipe) diameter must at least be 12.0 cm (4.8 inches). Install sensor in the centre.
- For mounting in metal pipes the inside pipe diameter (d) must be at least:

	MEdI = CLW.1		MEdI = CLW.2, OIL.1		MEdI = OIL.2, AUTO	
	[cm]	[inch]	[cm]	[inch]	[cm]	[inch]
d	4.0	1.6	6.0	2.4	10.0	4.0

6.3.1 Marking of the installation height

- ▶ Fix the set installation height with the supplied stainless steel tube clip.

If the sensor is removed from the fixture for maintenance reasons, the clip serves as a limit stop when remounting the sensor. Thus an inadvertent maladjustment of the sensor is excluded. This is in particular necessary for the correct function of the overflow prevention.

- ▶ Fit the stainless steel tube clip using pliers.
- ▶ Ensure a safe fit.
- ▶ To remove the clip it has to be destroyed.

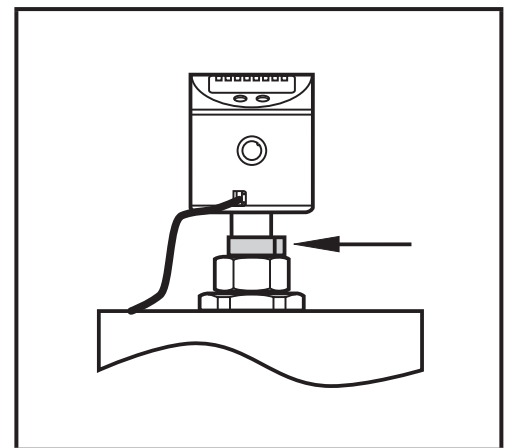

7 Electrical connection



The unit must be connected by a qualified electrician.

The national and international regulations for the installation of electrical equipment must be adhered to.

Voltage supply according to EN 50178, SELV, PELV.

▶ Disconnect power.

▶ Connect the unit as follows:

Core colours			
Pin	Socket	ifm	to DIN 47100
1	BN	brown	white
2	WH	white	brown
3	BU	blue	green
4	BK	black	yellow
5	GY	grey	grey
6	PK	pink	pink
7	VT	violet	blue

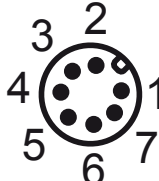
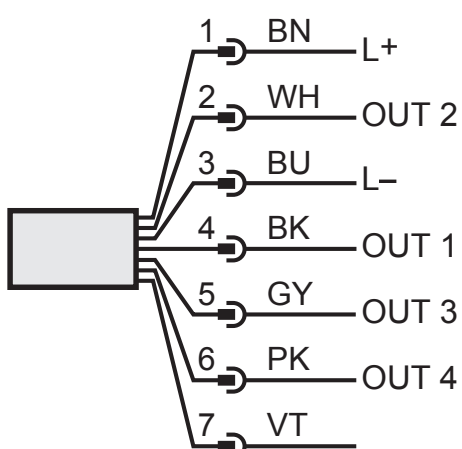
	OUT1: / IO-Link
	OUT2: Switching output (level)
	OUT3: Switching output (level / temperature)
	OUT4: Switching output (level / temperature)
	Colours to ifm

Example circuits

4 x positive switching

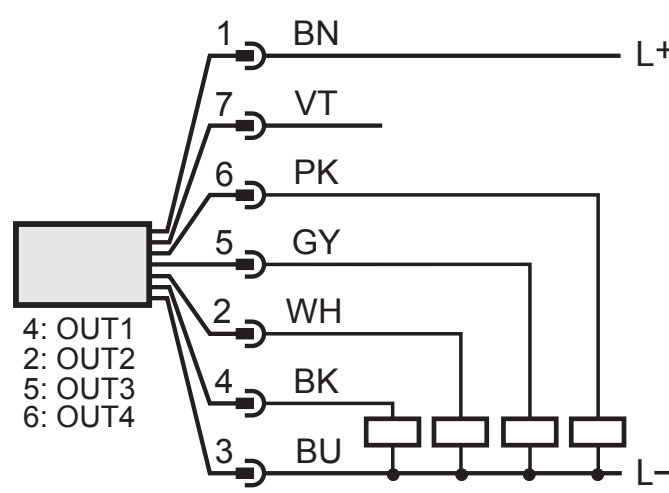

4: OUT1
2: OUT2
5: OUT3
6: OUT4

4 x negative switching

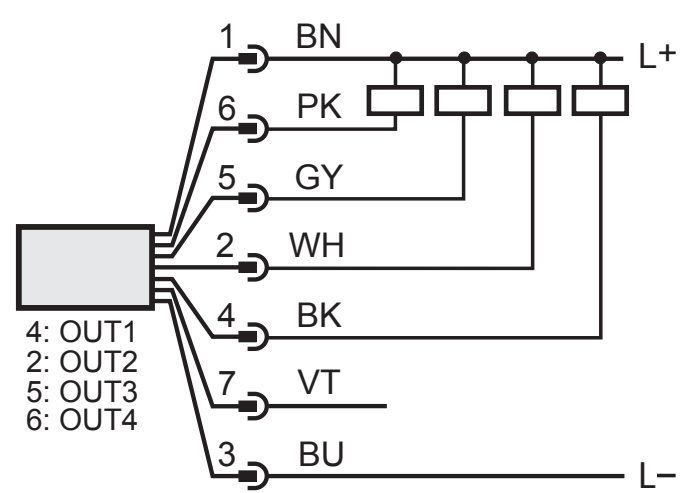

4: OUT1
2: OUT2
5: OUT3
6: OUT4



For safe function, the sensor housing must be electrically connected to the counter-electrode (grounding).

- ▶ Use the housing connection (see drawing) and a short piece of cable with a wire cross section of min. 1.5 mm².

When using metal tanks, the tank wall serves as the machine earth.

For plastic tanks, a counter-electrode must be provided, e.g. a metal plate inside the tank in parallel with the probe. Adhere to minimum distances to the probe.

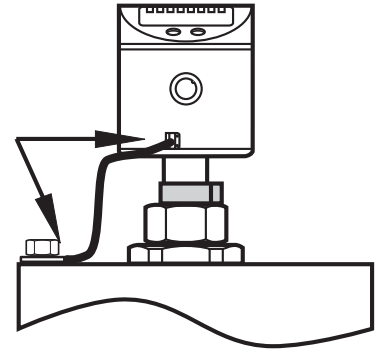

UK

8 Operating and display elements

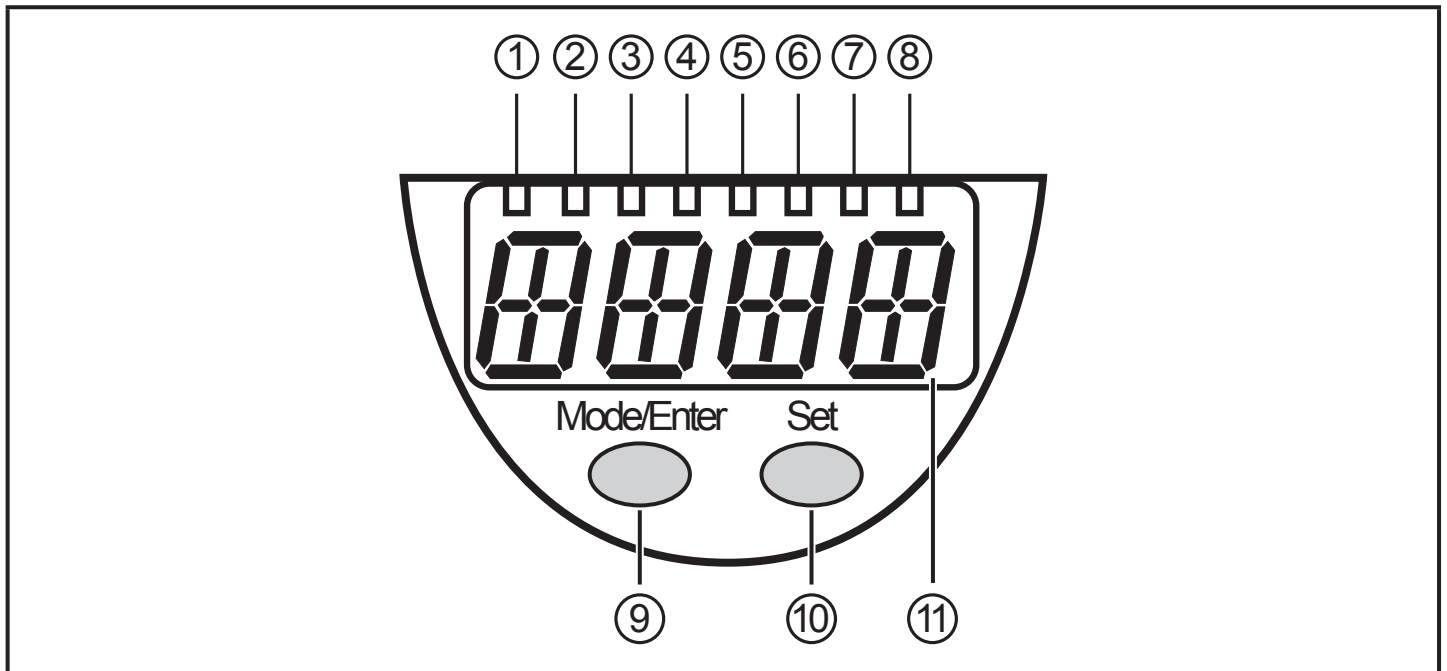

1 to 8: Indicator LEDs

LED 1	Indication in cm
LED 2	Indication in inches
LED 3	Indication in °C
LED 4	Indication in °F
LED 5	Switching status OUT4 (lights when output 4 is switched)
LED 6	Switching status OUT3 (lights when output 3 is switched)
LED 7	Switching status OUT2 (lights when output 2 is switched)
LED 8	Switching status OUT1 (lights when output 1 is switched)

9: [Mode/Enter] button

- Selection of the parameters and acknowledgement of the parameter values

10: [Set] button

- Setting of the parameter values (continuously by holding pressed; incremental by pressing once).

11: Alphanumeric display, 4 digits

- Display of the current level / the current temperature.
- Indication of the parameters and parameter values.
- Display of the operating and fault indication.

9 Menu

9.1 Menu

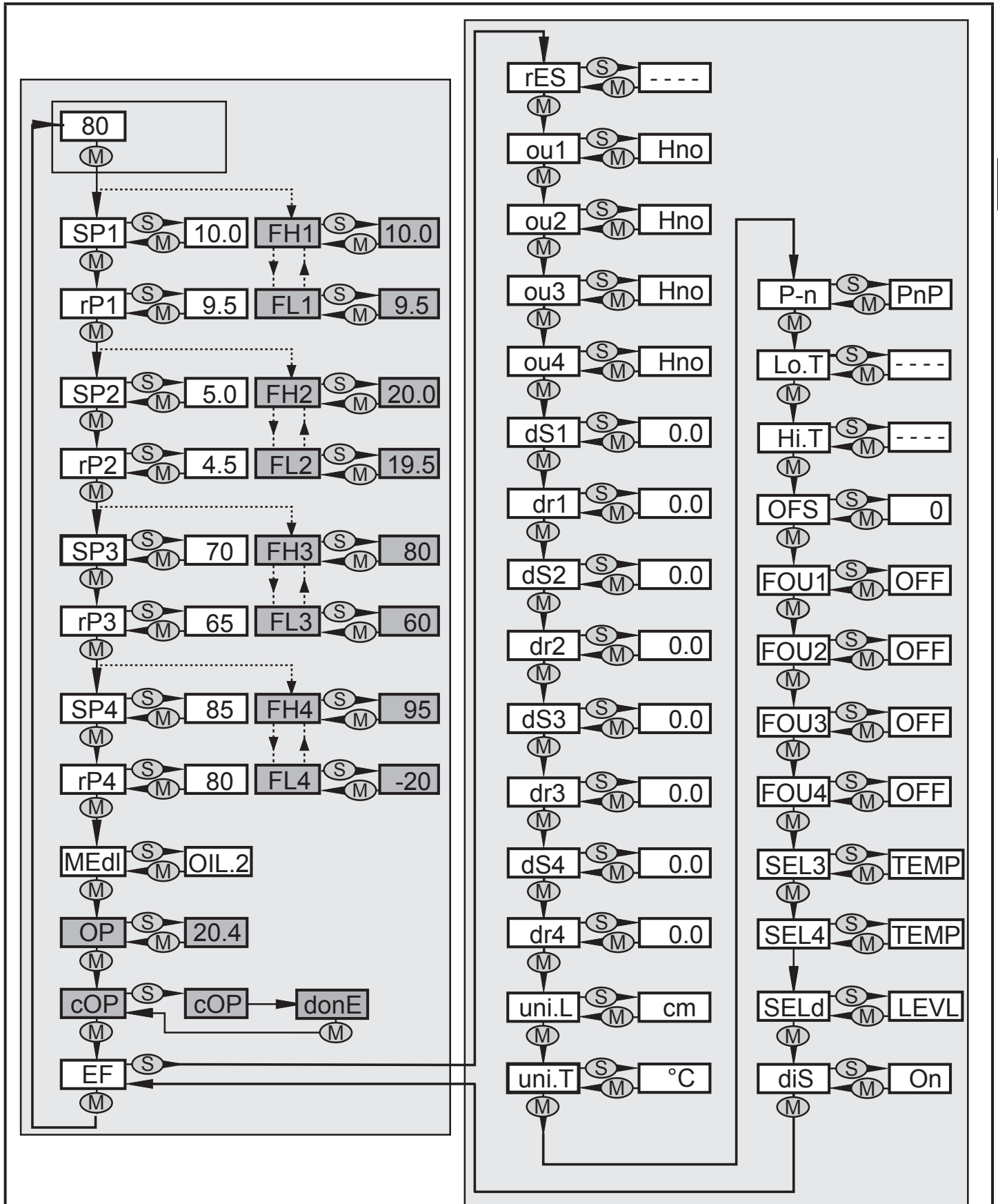

UK



Menu items highlighted in grey, e.g. [cOP], are only active when assigned parameters have been selected.

10 Parameter setting



CAUTION!

The surface of the unit may get hot if the switching outputs are operated at maximum load.

- > Risk of burns
- ▶ Do not touch the unit
- ▶ Use another object (e.g. a ballpoint pen) to carry out settings on the unit.

10.1 Parameter setting in general

1			<ul style="list-style-type: none"> ▶ Press [Mode/Enter] until the requested parameter is displayed. To select parameters in the extended menu (menu level 2): ▶ Select [EF] and briefly press [Set].
2			<ul style="list-style-type: none"> ▶ Press and hold [Set]. > The current parameter value flashes for 5 s. > Value is increased* (step by step by pressing the button once or continuously by keeping the button pressed).
3			<ul style="list-style-type: none"> ▶ Briefly press [Mode/Enter] (= confirmation). > The parameter is displayed again; the new parameter value becomes effective.
4	<p>Change more parameters:</p> <ul style="list-style-type: none"> ▶ Start again with step 1. 		<p>Finishing the parameter setting:</p> <ul style="list-style-type: none"> ▶ Wait for 30 s or press and hold [Mode/Enter]. > The current measured value is displayed. ▶ Release [Mode/Enter], > The parameter setting is completed.

*) Decrease the value: let the display move to the maximum setting value.

Then the cycle starts again at the minimum setting value.

Timeout: If no button is pressed for 30 s during programming, the unit returns to the operating mode with unchanged values (exception: cOP).

Locking / unlocking: The unit can be locked electronically to prevent unauthorised setting (factory setting: not locked).

► Make sure that the unit is in the normal operating mode.

To lock the unit:

► Press both buttons simultaneously for 10 s.
> [Loc] is displayed.

For unlocking:

► Press both buttons simultaneously for 10 s.
> [uLoc] is displayed.



The unit can be configured before or after installation.

Exemption: To adjust the overflow prevention [cOP], the unit must be installed in the tank.

10.2 Basic settings

Setting ranges of all parameters: → 13

Factory settings of all parameters: → 15

10.2.1 Assign process values to the outputs [SEL3] / [SEL4]

Outputs OUT1 and OUT2: assigned to the process value level.

Outputs OUT3 and OUT4: programmable.

<p>► Select [SEL3] / [SEL4]</p> <p>► Assign process value to the output OUT3 / OUT4:</p> <p>[LEVL] = The process value level is assigned to the output.</p> <p>[TEMP] = The process value temperature is assigned to the output.</p>	<p>SEL3</p> <p>SEL4</p>
--	---------------------------------------

10.2.2 Assign process value to the display [SELd]

<p>► Select [SELd]</p> <p>► Select process value that is to be displayed:</p> <p>[LEVL] = The process value level is displayed.</p> <p>[TEMP] = The process value temperature is displayed.</p>	<p>SELd</p>
---	--------------------

10.2.3 Define unit of measurement for level [uni.L]



▶ Enter [uni.L] before the limits for level are entered.

This avoids unintentional maladjustments.

<p>▶ Select [uni.L]</p> <p>▶ Define unit of measurement for the level:</p> <p>[cm] = level in cm</p> <p>[inch] = level in inches</p>	uni.L
--	--------------

10.2.4 Set the unit of measurement for the temperature [uni.T]



▶ Enter [uni.L] before the limits for temperature are entered.

This avoids unintentional maladjustments.

<p>▶ Select [uni.T]</p> <p>▶ Set unit of measurement for the temperature:</p> <p>[°C] = temperature in °Celsius</p> <p>[°F] = temperature in °Fahrenheit</p>	Uni.T
--	--------------

10.2.5 Set the offset [OFS]

The distance between tank bottom and lower edge of the measuring probe can be entered as offset value (→ 5.3.4).



▶ Set [OFS] before entering the values for SPx, rPx or OP.

This avoids unintentional maladjustments.

<p>▶ Select [OFS].</p> <p>▶ Set the value for the offset.</p> <p>Note the set unit of measurement [uni.L].</p>	OFS
--	------------

10.2.6 Set the medium [MEdI]

<p>▶ Select [MEdI] and set the corresponding sensitivity:</p> <p>[CLW.1] = water, hydrous media, coolant emulsions.</p> <p>[CLW.2] = water, hydrous media, coolant emulsion for temperatures > 35 °C (installation in climatic tube).</p> <p>[OIL.1] = oils with an increased dielectric constant (e.g. some synthetic oils).</p> <p>[OIL.2] = oils with a low dielectric constant (e.g. mineral oils).</p> <p>[Auto] = automatic medium detection.</p>	MEdI
--	-------------

- ▶ In case of doubt, select [OIL.2] for oils.
- ▶ Test proper functioning in an application test.



The settings [CLW.1] and [CLW.2] suppress deposits (e.g. metal swarf).
The settings [OIL.1] and [OIL.2] suppress a bottom layer of higher dielectric water or swarf which is a few cm high. If no oil layer is present (or if it is very thin), the bottom layer is detected.

UK

With the setting [MEdl] = [Auto], **no** overflow prevention is available. In that case, the menu items [OP] and [cOP] are not available.

10.2.7 Set the overflow prevention [OP]

<ul style="list-style-type: none"> ▶ Comply with minimum distances and installation instructions. ▶ Select [OP]. ▶ Define the position of the overflow prevention OP. <p>The option [OP] = [OFF] deactivates the overflow prevention OP.</p>	<p>OP</p>
--	------------------



- ▶ Set [OP] before [SPx] or [FHx].
- > [SPx] / [FHx] decreases if [OP] is reduced to a value \leq [SPx] / [FHx] after setting [SPx] / [FHx].
- > If [OP] and [SPx] / [FHx] are close to each other (1 x step increment), [SPx] / [FHx] increases if [OP] increases.



When the overflow prevention is deactivated [OP] = [OFF] or [MEdl] = [OFF], the safe function of the sensor must be verified with particular care. Switch-on and switch-off processes and special operating states such as very full tanks, possible maintenance and cleaning operations are to be considered in the verification.



For setting [OP] = [OFF] the menu item [cOP] is not available.

10.2.8 Adjust the overflow prevention [cOP]

Only adjust the overflow prevention OP when the unit is installed.

If possible, carry out the adjustment when the tank is empty.



The tank may be partly filled.

- ▶ Make sure that the overflow prevention OP is **not** covered by the medium. Observe the minimum distance between the overflow prevention OP and the level (→ Table 10-1).

<ul style="list-style-type: none"> ▶ Select [cOP]. ▶ Press [SET] and keep it pressed. > [cOP] flashes for some seconds; then the continuous display indicates that the adjustment is being made. > If the adjustment is successful, [donE] is displayed. ▶ Confirm with [Mode/Enter]. > If the adjustment is not successful, [FAIL] is displayed. ▶ If necessary, lower the level or correct the position of the overflow prevention [OP] and repeat the adjustment operation. 	cOP
--	-----

Minimum distance between the overflow prevention OP and the level during adjustment:

Table 10-1		
	[cm]	[inch]
LT8022	2.0	0.8
LT8023	3.5	1.4
LT8024	5.0	2.0



The position of the overflow prevention OP can be determined by calling up the parameter [OP]. Note the offset if necessary.

The current level is to be determined manually since the unit is not yet ready for operation before the adjustment.



When the overflow prevention is activated ([OP] = [value]), an adjustment [cOP] must be carried out each time:

- [MEdl] or [OP] were changed. In this case $\equiv \equiv \equiv$ is displayed.
- The installation position (height, orientation) was changed.
- The connection between the sensor and the tank ground (e.g. cable length) was changed.



With deactivated overflow prevention [MEdI] = [Auto] or [OP] = [OFF] it is necessary for the unit for applying the basic settings and adaptation to the medium and installation environment:

1. to be installed in the application.
2. to be reinitialised.
 - ▶ Switch the operating voltage off and on again.

10.3 Setting of output signals

UK

10.3.1 Set output function [oux] für OUT1...OUT4

<p>▶ Select [oux] and adjust the switching function:</p> <p>[Hno] = hysteresis function / normally open [Hnc] = hysteresis function / normally closed [Fno] = window function / normally open [Fnc] = window function / normally closed</p> <p>If the switching output is used as an overflow prevention, the setting [oux] = [Hnc] (NC function) is recommended. The principle of normally closed operation ensures that wire break or cable break is also detected.</p>	<p>ou1 ... ou4</p>
--	--

10.3.2 Define the switching limits [SPx] / [rPx] (hysteresis function)

<p>▶ Make sure that the function [Hno] or [Hnc] is set for [oux].</p> <p>▶ Set [SPx] first, then [rPx].</p> <p>▶ Select [SPx] and set the value at which the output is set.</p> <p>▶ Select [rPx] and set the value at which the output resets.</p>	<p>SP1 ... SP4</p>
	<p>rP1 ... rP4</p>

[rPx] is always smaller than [SPx]. The unit only accepts values which are lower than the value for [SPx]. If [SPx] is shifted, [rPx] also shifts provided that the lower end of the setting range is not reached.

10.3.3 Define switching limits [FHx] / [FLx] (window function)

<ul style="list-style-type: none"> ▶ Make sure that for [oux] the function [Fno] or [Fnc] is set. ▶ Set [FHx] first, then [FLx]. ▶ Select [FHx] and set the upper limit of the acceptable range. ▶ Select [FLx] and set the lower limit of the acceptable range. 	FH1 ... FH4
	FL1 ... FL4

[FLx] is always lower than [FHx]. The unit only accepts values which are lower than the value for FHx. If [FHx] is shifted, [FLx] also shifts provided that the lower end of the setting range is not reached.

10.3.4 Set set delay [dSx]

<ul style="list-style-type: none"> ▶ Select [dSx] and set the value between 0.0 and 60 s. <p>The switching delay reacts according to VDMA.</p>	dS1 ... dS4
---	---------------------------------

10.3.5 Set reset delay [drx]

<ul style="list-style-type: none"> ▶ Select [drx] and set the value between 0.0 and 60 s. <p>The switching delay reacts according to VDMA.</p>	dr1 ... dr4
---	---------------------------------

10.3.6 Define switching logic [P-n]

<ul style="list-style-type: none"> ▶ Select [P-n] and set [PnP] or [nPn]. 	P-n
--	------------

10.3.7 Define response of the outputs in case of a fault [FOUx]

<ul style="list-style-type: none"> ▶ Select [FOUx] and set value: <p>[On] = Output switches ON in case of a fault. Analogue output switches on > 21 mA / 10 V in case of a fault.</p> <p>[OFF] = Output switches OFF in case of a fault. Analogue output switches on < 3.6 mA / 0 V in case of a fault.</p> <p>[OU] = Output reacts according to process value (if possible).</p> <p>A hardware fault, too low a signal quantity, overtemperature or undertemperature are considered to be a fault. Overflow is not considered to be a fault. (→ 12.5)</p>	FOU1 ... FOU4
---	-----------------------------------

10.3.8 Configure display [diS]

<p>▶ Select [diS] and set value:</p> <p>[On] = The display is switched on in the operating mode. Update of the measured values every 500 ms</p> <p>[OFF] = The display is switched off in the operating mode. When one of the buttons is pressed, the current measured value is displayed for 30 s. The indicator LEDs remain active even if the display is deactivated.</p>	diS
--	------------

UK

10.3.9 Reset all parameters to factory settings [rES]

<p>▶ Select [rES].</p> <p>▶ Press and hold [Set] until [----] is displayed.</p> <p>▶ Briefly press [Mode/Enter].</p> <p>> The unit reboots and the factory settings are restored.</p>	rES
--	------------

11 Notes on parameter setting via IO-Link



On delivery the LT80xx-type unit is not operational.

First, the integrated overflow prevention OP has to be adjusted.

Depending on the application, OP adjustment can be carried out in different ways:

- directly on the display (→ 10).
- via an IO-Link tool (e.g. LR DEVICE), button "Teach_OP [cOP]".
- via the controller: write the value 208 to the IO-Link index 2 (length: 1 byte).



The OP adjustment is not part of the data storage.

Therefore, a simple replacement (e.g. in case of a unit failure) is only possible with reservations: On the new unit, the OP adjustment has to be carried out manually, either via the operating keys or via IO-Link. Only when the OP adjustment has been carried out successfully does the unit revert to the cyclical process data transmission.



After a factory reset (button "Restore Factory Settings"), the device reboots and the factory settings are restored.

12 Operation

After switch-on of the operating voltage, the unit is in the operating mode (= normal operating mode). It carries out its measurement and evaluation functions and generates output signals according to the set parameters.

► Check whether the unit operates correctly.

12.1 Operating indicators

[----] (continuous)	Initialisation phase after power on.
[numerical value] + LED 1	Current level in cm.
[numerical value] + LED 2	Current level in inches.
[numerical value] + LED 3	Current temperature in °C.
[numerical value] + LED 4	Current temperature in °F.
LEDs 5 - 8	Switching status OUT4...OUT1 (lights when the respective output is switched).
[UL]	Warning: temperature is below approx. -30 °C / -25 °F.
[OL]	Warning: temperature exceeds approx. +100 °C / +215 °F.
[----]	Level below the active zone.
[FULL] + [numerical value] alternately	The overflow prevention OP is reached (overflow warning) or the level is above the active zone.
≡≡≡≡	It is necessary to adjust [cOP] of the overflow prevention OP.
[Loc]	Unit locked via operating keys; parameter setting impossible. For unlocking press the two setting buttons for 10 s.
[uLoc]	Unit is unlocked / parameter setting is possible again.
[C.Loc]	The unit is temporarily locked. Parameter setting via IO-Link is active (temporary locking).
[S.Loc]	Unit is permanently locked via software. This locking can only be removed with a parameter setting software.

12.2 Read the set parameters

- Briefly press [Mode/Enter] (if required, repeat several times).
- > Menu items are passed through until the requested parameter has been reached.
- Briefly press [Set].
- > Respective parameter value is displayed for 30 s.

12.3 Read / reset extreme value memory temperature

- ▶ Select parameter [Lo.T] or [Hi.T]
- ▶ Briefly press [Set] for reading.
- > Device displays the stored maximum or minimum value for 30 s.
- ▶ To delete the memory keep [Set] pressed until [----] is displayed.
- ▶ Briefly press [Mode/Enter].

12.4 Fast selection level / temperature

In the operating mode:

- ▶ Briefly press [Set].
- > Display of the other process value for 30 s; the respective LED is lit.

12.5 Error indications

	Possible cause	Recommended measures
[Err]	Fault in the electronics.	▶ Replace the unit.
[SEnS]	<ul style="list-style-type: none"> • Interfering sources (e.g. EMC) • Poor cables • Problems with the supply voltage 	<ul style="list-style-type: none"> ▶ Check electrical connection. ▶ Check the connection between the sensor and the tank ground.
[FAIL]	Error during adjustment of the overflow prevention OP: <ul style="list-style-type: none"> • Overflow prevention covered by the medium during adjustment. • Overflow prevention soiled. • Minimum distances too short. • Mounting element detected below the overflow prevention. • Measured value not constant. 	<ul style="list-style-type: none"> ▶ Lower the level, if necessary. ▶ Clean the probe. ▶ Observe the notes on installation. ▶ Correct the position of the overflow prevention OP. ▶ Repeat the adjustment. ▶ Deactivate OP (→ 5.3.1).
[cr.UL]	Error: temperature is below approx. -40 °C / -45 °F.	▶ Check process temperature and correct, if necessary.
[cr.OL]	Error: temperature exceeds approx. +125 °C / +255 °F	▶ Check process temperature and correct, if necessary.
[SCx] + LEDs 5 - 8	Flashing: short circuit in switching output x	▶ Remove the short circuit.
[SC] + LEDs 5 - 8	Flashing: short circuit in all switching outputs.	▶ Remove the short circuit.
[PArA]	Faulty data set.	▶ Reset to factory settings [rES].

12.6 Output response in different operating states

	OUT1/2	OUT3/4
Initialisation phase	OFF	OFF
Overflow prevention OP not adjusted	OFF	According to process value and setting [oux]
Overflow prevention OP adjusted or deactivated, normal operation	According to process value and setting [oux]	
Fault	According to setting [FOUx]	

13 Technical data



Technical data and scale drawing at www.ifm.com

13.1 Setting values [OFS]

	[cm]		[inch]	
Setting range	0...200.0		0...78.8	
	LT8022 LT8023	LT8024	LT8022 LT8023	LT8024
Step increment	0.5	1	0.2	0.5



The values of the following tables apply if [OFS] = [0].
If [OFS] > [0], they increase by the set OFS value.

13.2 Setting ranges switching limits for level

	LT8022		LT8023		LT8024	
	[cm]	[inch]	[cm]	[inch]	[cm]	[inch]
[SPx] / [FHx]	2.5...20.0	1.0...7.8	3.5...39.0	1.4...15.4	6...59	2.5...23.5
[rPx] / [FLx]	2.0...19.5	0.8...7.6	3.0...38.5	1.2...15.2	5...58	2.0...23.0
Step increment	0.5	0.2	0.5	0.2	1	0.5

13.3 Setting ranges switching limits for temperature

Table 12-3		
	[°C]	[°F]
[SPx] / [FHx]	-19...90	-3...194
[rPx] / [FLx]	-20...89.5	-4...193
Step increment	0.5	1

UK

13.4 Setting values [OP]

Table 12-4					
LT8022		LT8023		LT8024	
[cm]	[inch]	[cm]	[inch]	[cm]	[inch]
20,4	8,0	40,7	16,0	61	23,9
19,1	7,5	38,3	15,1	57	22,4
17,9	7,1	35,8	14,1	53	21,0
16,7	6,6	33,4	13,1	50	19,5
15,5	6,1	31,0	12,2	46	18,1
14,3	5,6	28,5	11,2	42	16,7
13,0	5,1	26,1	10,3	39	15,2
11,8	4,7	23,6	9,3	35	13,8
10,6	4,2	21,2	8,3	31	12,3
9,4	3,7	18,8	7,4	28	10,9
8,2	3,2	16,3	6,4	24	9,5
6,9	2,7	13,9	5,5	20	8,0

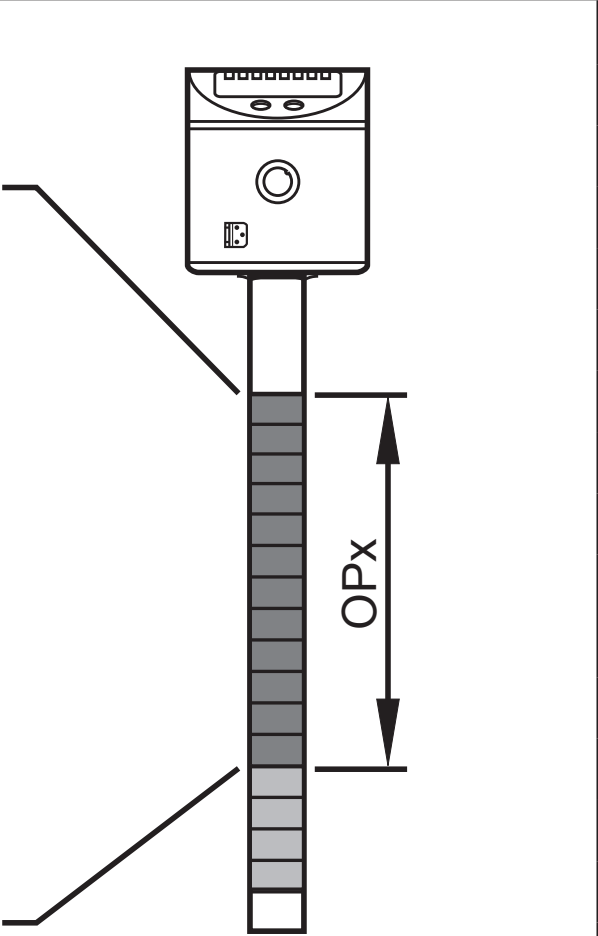

OPx: Setting range [OP]

The indicated values for [OP] refer to the distance between OP and the lower edge of the probe.

The values apply if [OFS] = [0].



With [OFS] > [0] the values increase by the set OFS value. Example LT8022: According to Table 12-4 OP has to be set to segment 20.4 cm.

[OFS] = 7.0 cm

[OP] is to be set to 20.4 cm + 7.0 cm = 27.4 cm.

13.5 Calculation aids [OP]



For proper functioning of the overflow prevention OP a minimum distance (y) (Fig. 12-1) must be observed (\rightarrow 6.1).

The following applies (Fig. 12-1):

$B + c = L + u$ and $B = z + y$	B: tank height c: outside length (maximal (\rightarrow 6)) y: required response level OP from the cover (minimum \rightarrow 6.3, maximum \rightarrow 13.4).	L: probe length u: distance between probe and tank bottom z: required response level OP from the bottom (maximum: $z < L - c - y$ or $z < B - y$).

13.5.1 Definition "from the cover"

Requested distance (y) of the overflow prevention OP "from the cover" is defined.

- Without offset ([OFS] = [0]): $[OP] = L - c - y$
- With offset ([OFS] = u): $[OP] = L - c - y + u$
or
 $[OP] = B - y$

Example LT8022:

$c = 3.0$ cm, $y = 5.0$ cm, $u = 1.0$ cm

Without offset: $[OP] = 26.4$ cm - 3.0 cm - 5.0 cm
= 18.4 cm

With offset: $[OP] = 26.4$ cm - 3.0 cm - 5.0 cm + 1.0 cm
= 19.4 cm

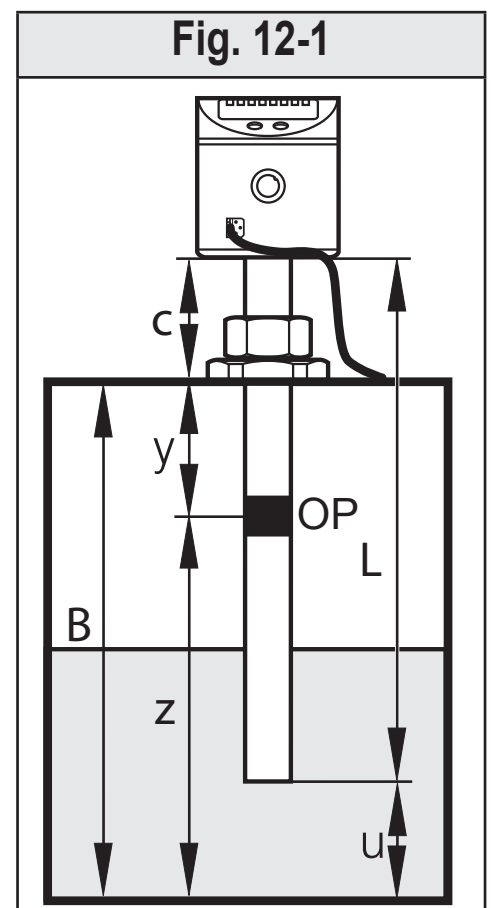

13.5.2 Definition "from the bottom"

Response level (z) of the overflow prevention OP from the tank bottom is defined.

- Without offset ([OFS] = [0]): $[OP] = z - u$
- With offset ([OFS] = u): $[OP] = z$

Example LT8022:

$z = 18.0$ cm (from the tank bottom), $u = 1.0$ cm

Without offset: $[OP] = 18.0$ cm - 1.0 cm = 17.0 cm

With offset: $[OP] = 18.0$ cm

Round the calculated value to the next lower adjustable value \rightarrow 13.4.

14 Maintenance / cleaning / change of medium

When removing or installing the unit for maintenance and cleaning work:

- ▶ Make sure that the stainless steel tube clip is fixed to the sensor.
- > It must be possible to exactly reproduce the installation height and position.
- ▶ Remove the sensor and clean it / carry out maintenance
- ▶ Install sensor exactly in the same position as before.
- ▶ Otherwise check the parameter [OP] and carry out [cOP] once again.

UK

14.1 Maintenance information for operation without overflow prevention

[MEdl] = [Auto] or [OP] = [OFF] (overflow prevention OP deactivated)

The unit must be reinitialised in the following cases (switch the operating voltage briefly off and on again):

- After all maintenance operations.
- After cleaning operations (e.g. water jet cleaning of the sensor probe).
- If the sensor was removed from the tank and then installed again during operation.
- If the active zone of the sensor was touched with the hand or grounded objects (e.g. a screwdriver, a cleaning lance).
- If the connection between the sensor and the tank wall/counter-electrode was changed.
- After a change of the medium with considerably differing dielectric constants. For manual selection of media, first the [MEdl] setting needs to be adjusted.

15 Factory setting

	Factory setting			User setting
	LT8022	LT8023	LT8024	
SP1	10.0 (cm)	19.5 (cm)	29 (cm)	
rP1	9.5 (cm)	19.0 (cm)	28 (cm)	
SP2	6.0 (cm)	10.0 (cm)	15 (cm)	
rP2	5.5 (cm)	9.5 (cm)	14 (cm)	
OP	20.4 (cm)	40.7 (cm)	61 (cm)	
SP3	65 (°C)			
rP3	62 (°C)			
SP4	70 (°C)			
rP4	67 (°C)			
MEdl	OIL.2			
cOP	----			
rES	----			
ou1...4	Hno			
dS1...4	0.0			
dr1...4	0.0			
uni.L	cm			
Uni.T	°C			
P-n	PnP			
Lo.T	----			
Hi.T	----			
OFS	0			
FOU1...4	OFF			
SEL3	TEMP			
SEL4	TEMP			
SELd	LEVL			
diS	On			

16 Applications

16.1 Storage tank

Level control and min / max monitoring with 4 switching outputs
(No temperature monitoring; [SEL3] and [SEL4] = [LEVL])

Replaces 4 float switches

Configuration of the switching outputs 1...4	
SP1	Maximum value exceeded → alarm.
ou1	Hysteresis function, normally closed (Hnc).
SP2	Upper preset value exceeded → finish refilling.
ou2	Hysteresis function, normally open (Hno).
SP3	Below lower preset value → start refilling.
ou3	Hysteresis function, normally closed (Hnc).
SP4	below min. value → alarm.
ou4b	Hysteresis function, normally open (Hno).
rP1...4	Each slightly below SPx to suppress wave movements.

UK

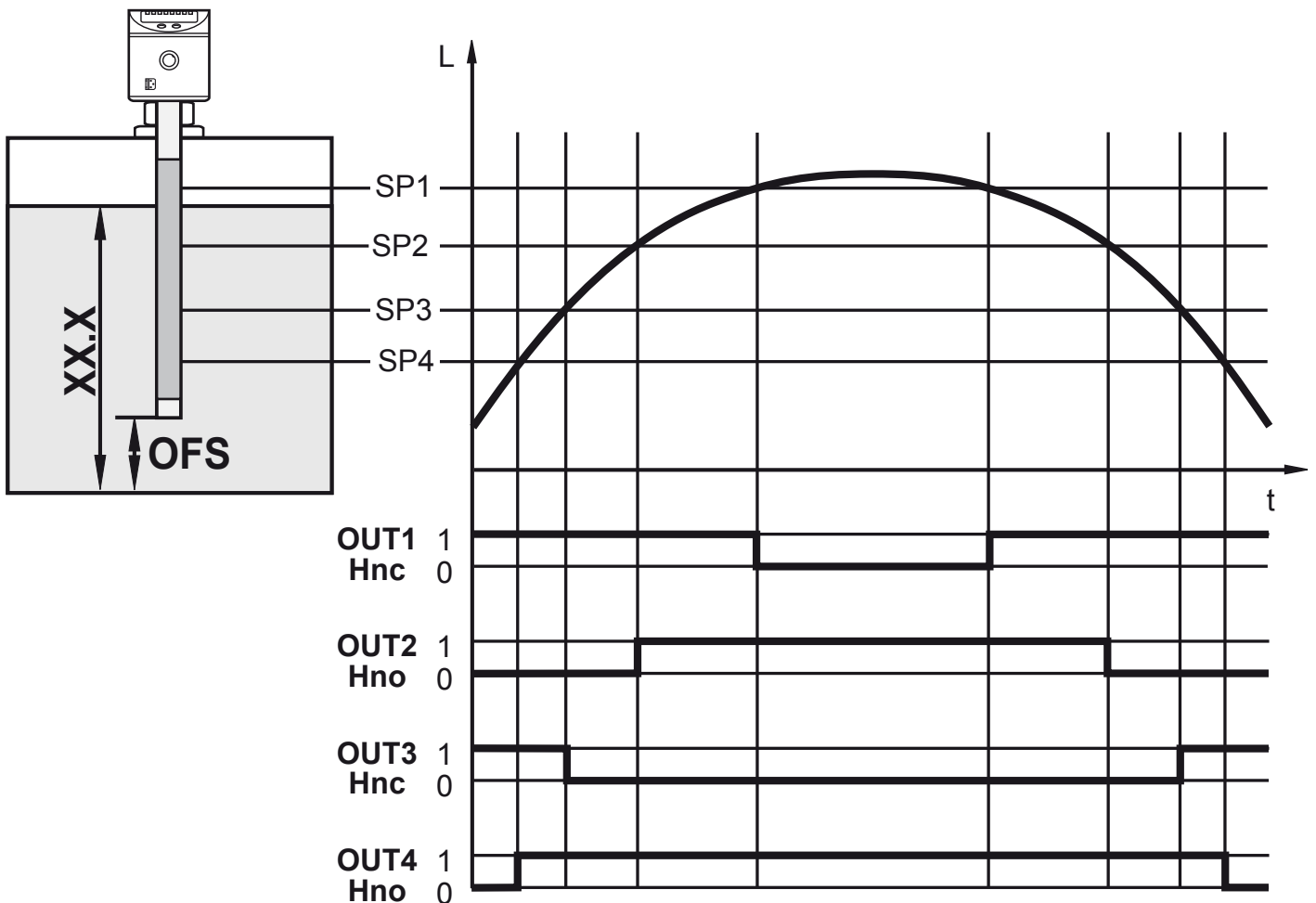

- If the level is below SP1, the output is switched. If the level is above SP1 or if there is a wire break, output 1 switches off (alarm message "overflow / wire break").
- If the level reaches SP2, output 2 switches (upper preset value reached; finish refilling).
- If the level is below SP3, output 3 switches (below lower preset value; start refilling).
- If the level is above SP4, the output is switched. If the level is below SP4 or if there is a wire break, output 4 switches off (alarm message "below min. value / wire break").

16.2 Pumping station

Empty the tank / overflow prevention with 3 switching outputs.

Output OUT4 can be used for temperature monitoring:

[SEL3] = [LEVL], [SEL4] = [TEMP]

Replaces 3 float switches and 1 temperature switch

Configuration of the switching outputs 1...3	
SP1	Maximum value exceeded → alarm.
ou1	Hysteresis function, normally closed (Hnc).
SP2	Upper value exceeded → submersible pump ON.
ou2	Hysteresis function, normally open (Hno).
SP3	Below the lower value → submersible pump OFF.
ou3	Hysteresis function, normally closed (Hnc).
rP1...3	Each slightly below SPx to suppress wave movements.

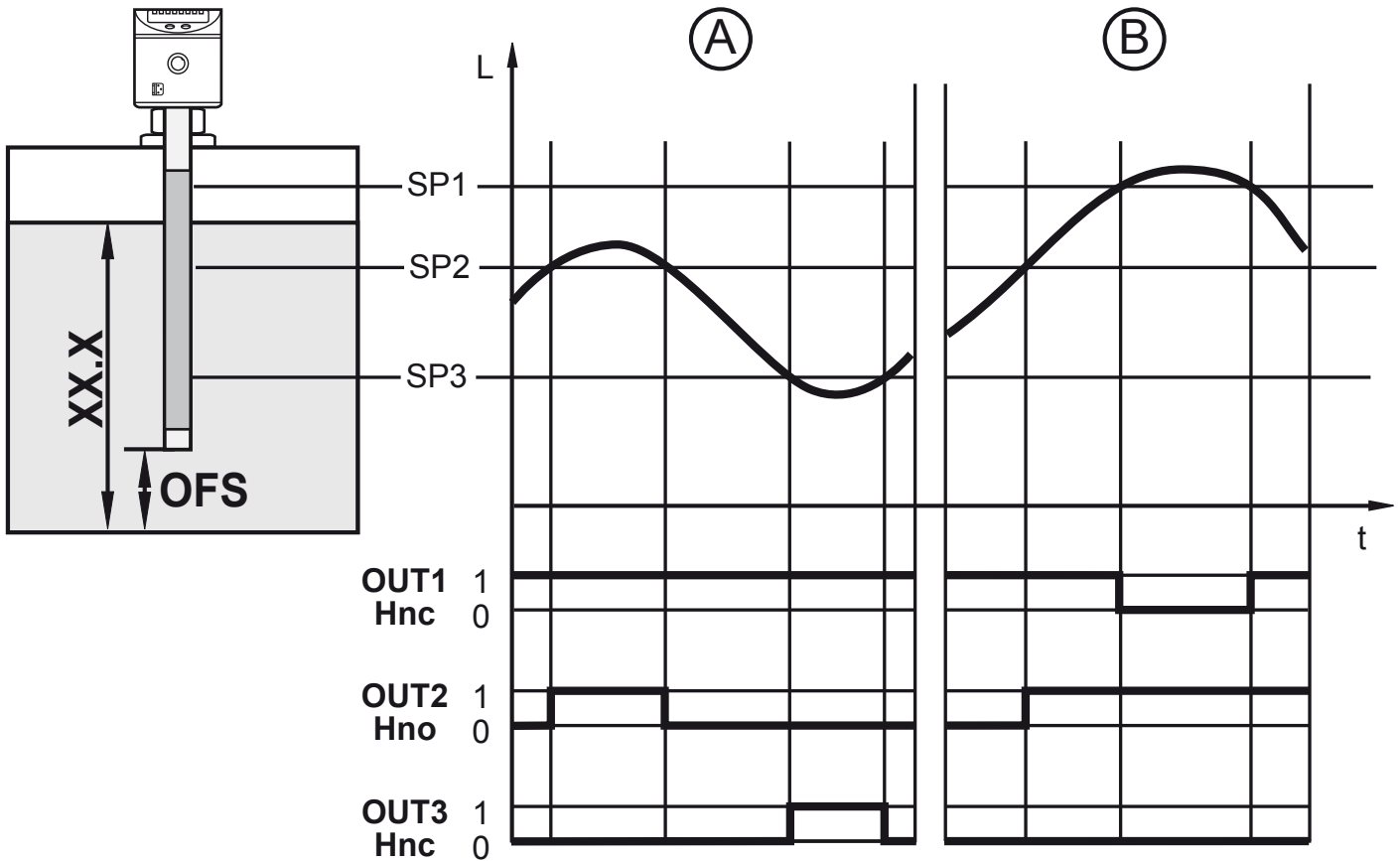

UK

- If the level is below SP1, the output is switched. If the level is above SP1 or if there is a wire break, output 1 switches off (alarm message "overflow / wire break").
- If the level exceeds SP2, output 2 switches (upper value exceeded; submersible pump ON).
- If the level is below SP3, output 3 switches (lower value reached; submersible pump OFF).
- Suggestion for temperature monitoring:
ou4 = Hnc
SP4 = 45 (°C)
rP4 = 40 (°C)
As long as the temperature is below SP4, the output switches. If the level is above SP4 or if there is a wire break, output 4 switches off (alarm message "overtemperature / wire break").

More information at www.ifm.com