

ifm electronic



Operating instructions
RFID evaluation unit

efector190[®]

DTE102

UK

706298 / 00 02 / 2013

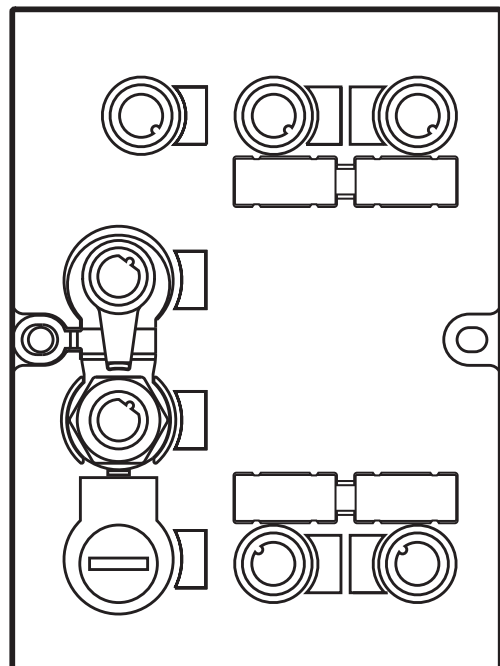

Contents

1	Preliminary note.....	4
1.1	Notes on this document.....	4
1.2	Symbols used	4
2	Safety instructions	4
2.1	General.....	4
2.2	Installation and connection	4
2.3	Tampering with the device	5
3	Functions and features	5
3.1	Configuration via Ethernet interface	5
3.2	RFID antennas	6
4	Function.....	6
5	Installation.....	6
5.1	Installation distance	6
5.2	Installation orientation.....	7
5.3	Mounting options	7
5.3.1	Mounting on DIN rail.....	7
5.3.2	Removal	8
5.3.3	Mounting plate	8
6	Electrical connection.....	9
6.1	AUX voltage supply	9
6.2	Field bus connection EtherNet/IP Port 1 / Port 2.....	10
6.2.1	Factory setting of the Ethernet parameters	10
6.3	Process connections IO-1 ... IO-4	11
6.4	Functional earth connection.	12
6.4.1	Mounting on DIN rail.....	12
6.4.2	Mounting plate	12
7	Operating and display elements	13
7.1	Reset to factory settings	13
7.2	LED indicators	13
7.2.1	LED AUX	13
7.2.2	LED EtherNet/IP Port 1 / Port 2.....	14
7.2.3	LED Mod (module status).....	14
7.2.4	LED Net (network status)	15

7.2.5 LEDs IO1 ... IO4	16
7.2.6 Special device- LED indications	18
8 Technical data.....	18
8.1 Data sheets	18
8.2 Device manual	18
9 Maintenance, repair and disposal.....	19
10 Approvals/standards	19
11 Scale drawing	19

UK

Licences and trademarks

Microsoft® und Internet Explorer® are registered trademarks of Microsoft Corporation. All trademarks and company names are subject to the copyright of the respective companies.

1 Preliminary note

1.1 Notes on this document



This document applies to the RFID evaluation unit DTE102.

It is part of the device and contains information about the correct handling of the product.

This document is intended for qualified electricians. These specialists are people who are qualified by their training and their experience to see and to avoid possible hazards that may be caused during operation of the device.

Read this document before use to familiarise yourself with operating conditions, installation and operation. Keep this document during the entire duration of use of the device.

1.2 Symbols used

- ▶ Instructions
- > Reaction, result
- [...] Designation of pushbuttons, buttons or indications
- Cross-reference
-  Important note
Non-compliance can result in malfunction or interference.
-  Information
Supplementary note

2 Safety instructions

2.1 General

- ▶ Observe these operating instructions.
- ▶ Adhere to the warning notes on the product.

Non-observance of the instructions, operation which is not in accordance with use as prescribed below, wrong installation or incorrect handling can affect the safety of operators and machinery.

2.2 Installation and connection

The device must only be installed, connected and put into operation by a qualified electrician as the safe function of the device and machinery is only guaranteed when installation is correctly carried out. The installation and connection must

comply with the applicable national and international standards. Responsibility lies with the person installing the device.



This is a class A product. The device may cause radio interference in domestic areas. In this case it can be necessary for the user to take appropriate measures.

2.3 Tampering with the device

Tampering with the device is not allowed and will lead to an exclusion of liability and warranty. Tampering with the device can affect the safety of operators and machinery.

- ▶ Do not open the device.
- ▶ Do not insert any objects into the device.
- ▶ Prevent metal foreign bodies from penetrating.

3 Functions and features

The RFID evaluation unit DTE102 integrates an EtherNet/IP interface and 4 channels for the connection of field devices. Each channel can be used either for the connection of an RFID antenna or as input/output to IEC 61131.

The device

- controls the data exchange to the RFID antennas or the sensor/actuator level.
- communicates with the higher-level control level via EtherNet/IP.
- allows device configuration via a web server.

Application examples:

- Material flow control in production lines
- Warehouse management by the automatic detection of stored products
- Tank management, order picking or product tracking

3.1 Configuration via Ethernet interface

- 10 Mbps and 100 Mbps
- TCP / IP - Transport Control Protocol / Internet Protocol
- UDP - User Datagram Protocol
- IT functionality: HTTP server
- M12, twisted pair

3.2 RFID antennas

The device supports up to four RFID read/write heads of type ANT51x from ifm electronic gmbh.

You can find information about the matching read/write heads on our website at:

www.ifm.com → data sheet search → ANT51

4 Function

You can find detailed information about the function of the system in the device manual at:

www.ifm.com → data sheet search → DTE102 → Operating instructions

5 Installation

5.1 Installation distance

Due to the internal heating of the device a minimum distance to other objects of 10 mm is to be taken into account during installation.

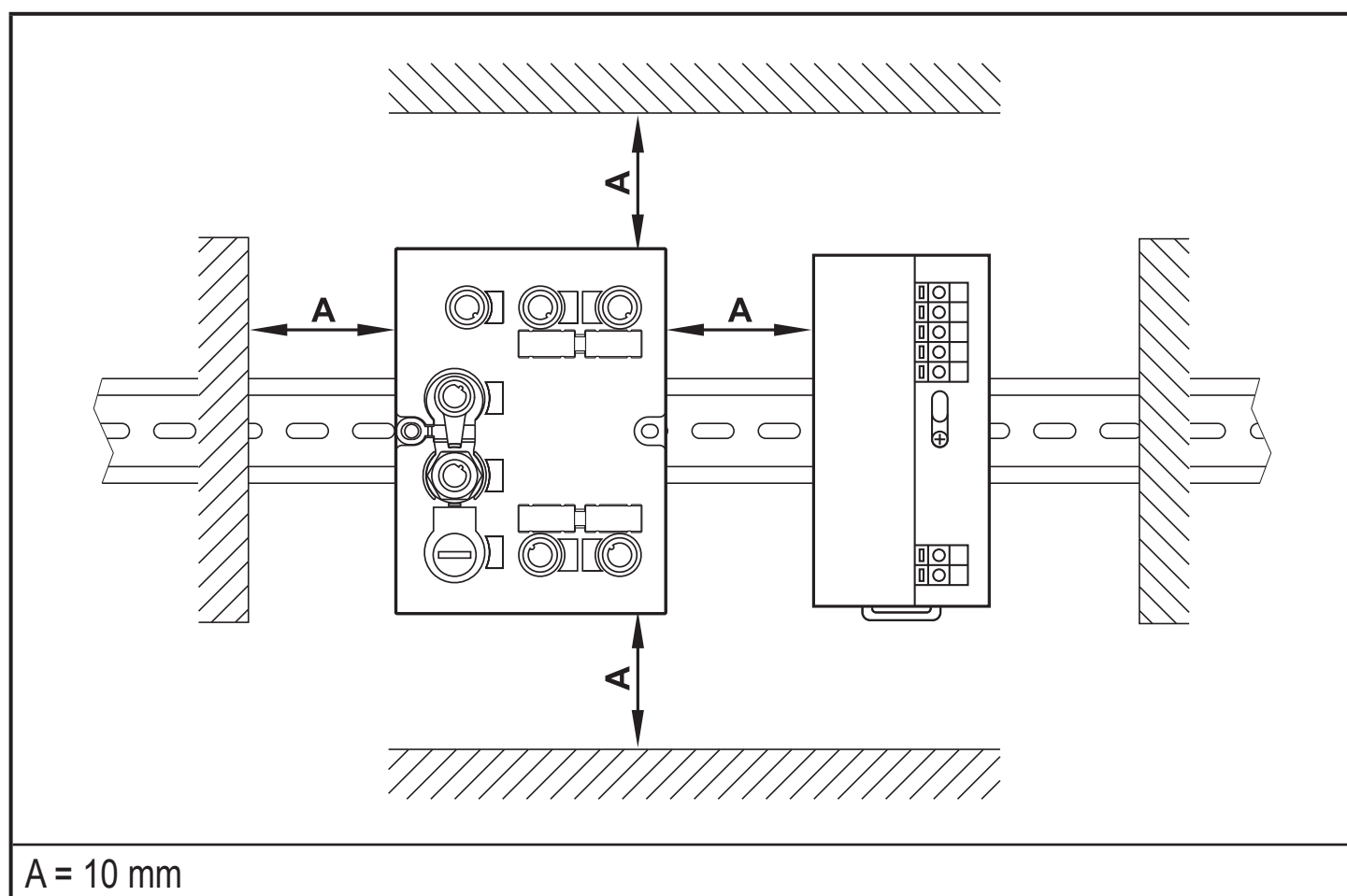

5.2 Installation orientation

The installation orientation can be freely selected.



In a wet environment upside-down mounting is not permitted.

5.3 Mounting options

5.3.1 Mounting on DIN rail

The device can be installed on a DIN rail of type NS35/15 or NS35/7.5.

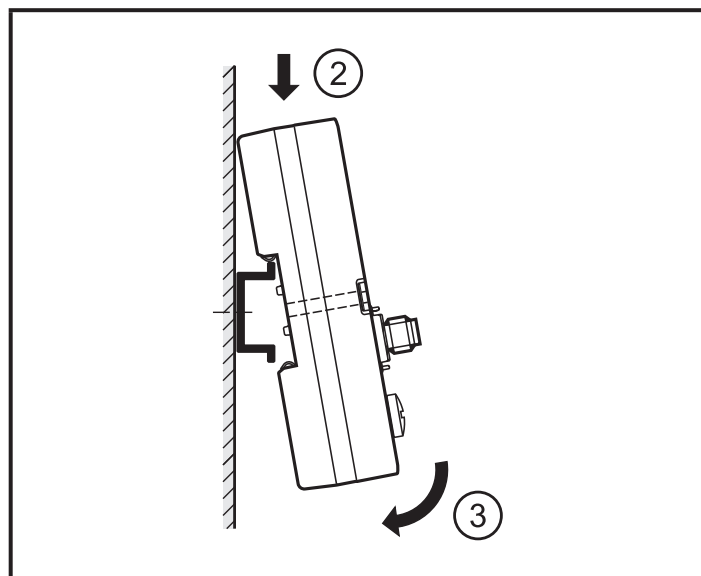
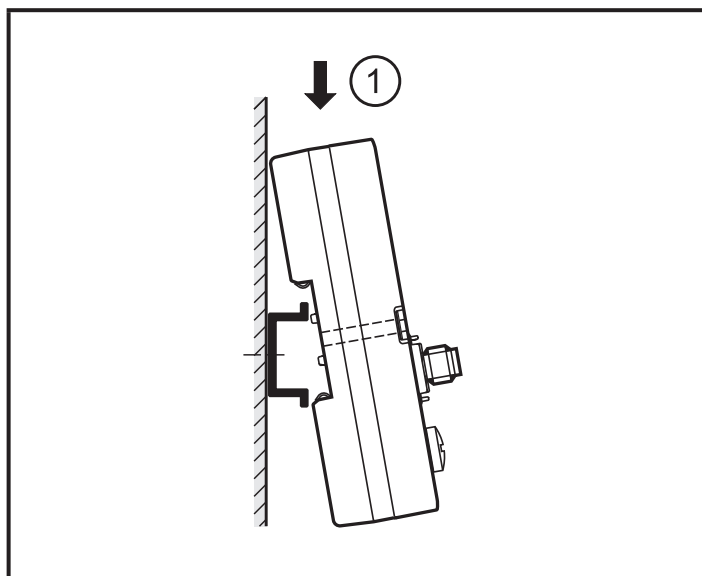

UK

1. Angle the device and place the fixing clamp onto the upper edge of the DIN rail.
2. Press device down.
3. Simultaneously rotate the device in the direction of the DIN rail.

5.3.2 Removal

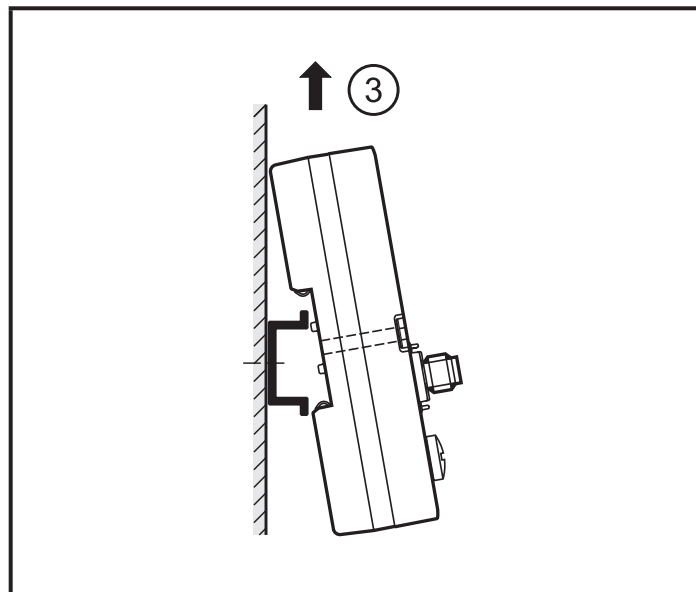
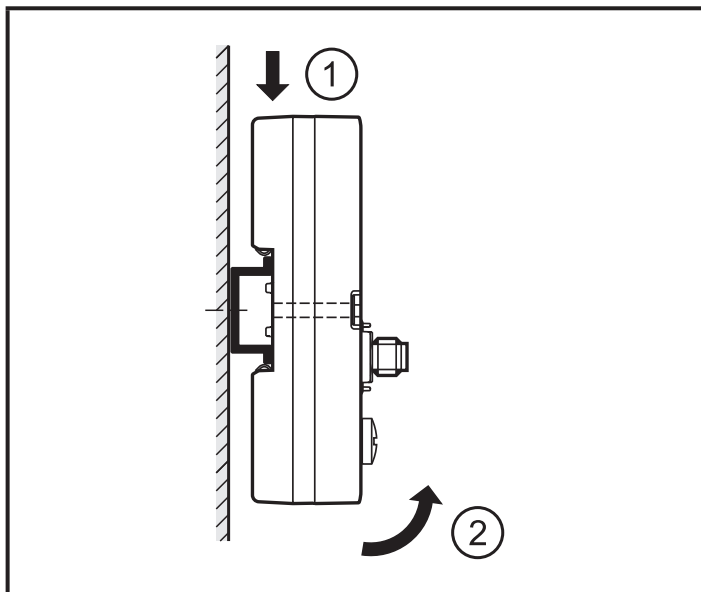

1. Press device down.
2. Simultaneously rotate the device away from the DIN rail.
3. Remove the device from the top.

5.3.3 Mounting plate

The device can be fixed to a mounting plate using 2 screws (M4 x 35 or longer).

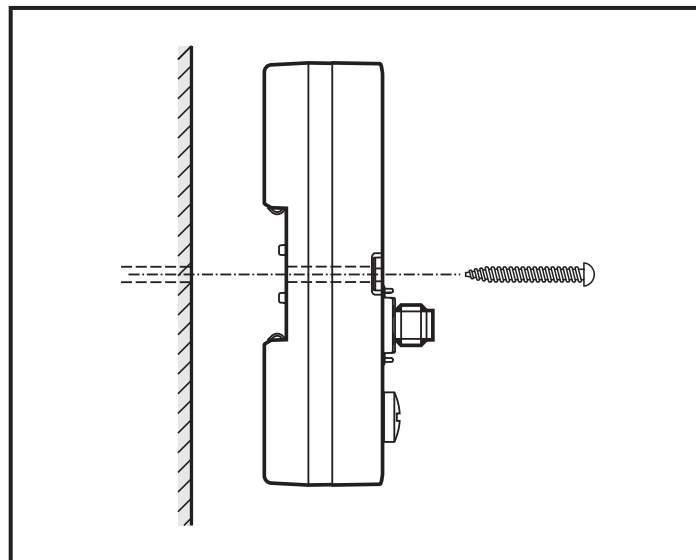
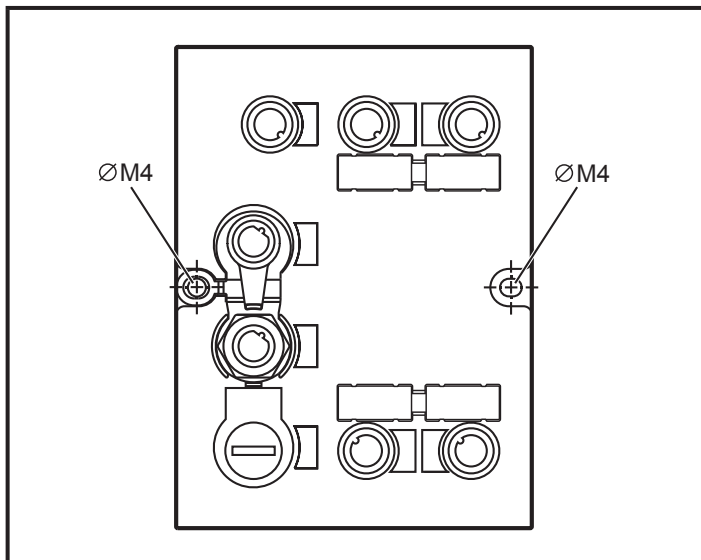

This installation mode is recommended for vibration and shock requirements.

6 Electrical connection



The device must be connected by a qualified electrician.

- ▶ Disconnect power before connecting the device.
- ▶ Observe the national and international regulations for the installation of electrical equipment.
- ▶ Ensure voltage supply to EN 50178, SELV, PELV.
- ▶ Connect the device according to the indicated pin connection.
- ▶ A total current consumption of the device of 3 A must not be exceeded.

UK

Please note the following points to ensure protection rating IP 67:

- ▶ Cover the unused sockets with protective caps.
- ▶ Tighten all protective caps and connectors with a tightening torque of 1 Nm.

You will find matching accessories at www.ifm.com

Accessories	ifm article number
Protective cap	E73004
Torque wrench	E70390

6.1 AUX voltage supply

- ▶ Connect the device to the voltage supply using an M12 connection cable.

	Pin	Connection
	1	24 V DC
	2	Not used
	3	0 V
	4	Not used
	5	Not used

You can find matching connection cables at:

www.ifm.com → data sheet search → DTE102 → Accessories

6.2 Field bus connection EtherNet/IP Port 1 / Port 2

- ▶ Connect the device to an EtherNet/IP master using a suitable M12 Ethernet connection cable.

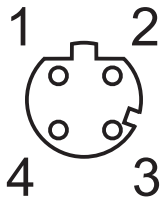
 Note: screened connection cable required	Pin	Connection
	1	TD+
	2	RD+
	3	TD-
	4	RD-

6.2.1 Factory setting of the Ethernet parameters

The following values are preset on delivery of the device:

Parameters	Factory setting
IP address	192.168.0.79
Gateway address	192.168.0.100
Subnet mask	255.255.255.0
Auto-negotiation	on
DHCP	off

The settings can be changed via the webserver of the device or via the TCP/IP interface object of the EtherNet/IP bus.

6.3 Process connections IO-1 ... IO-4

Each process connection can be used as input/output to IEC 61131 or for connection of an RFID read/write head. The connections are set via the hardware configuration of the EtherNet/IP master.

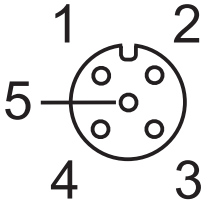
	Pin	Connection
	1	L+
	2	Switching input (I/Q)
	3	L-
	4	Switching output (C/Qo) or input (C/Qi)
	5	Not used

 The evaluation unit has to be disconnected before field units are connected.

 Please note that the total current consumption of the device must not exceed the value of 3 A.

You can find detailed information about the available operating modes in the device manual at:

www.ifm.com → data sheet search → DTE102 → Operating instructions

6.4 Functional earth connection.



To ensure trouble-free operation the device must be connected to an earth potential free from external voltage.

6.4.1 Mounting on DIN rail

The connection is made automatically via the DIN rail. Note that the DIN rail must be connected with the earth potential.

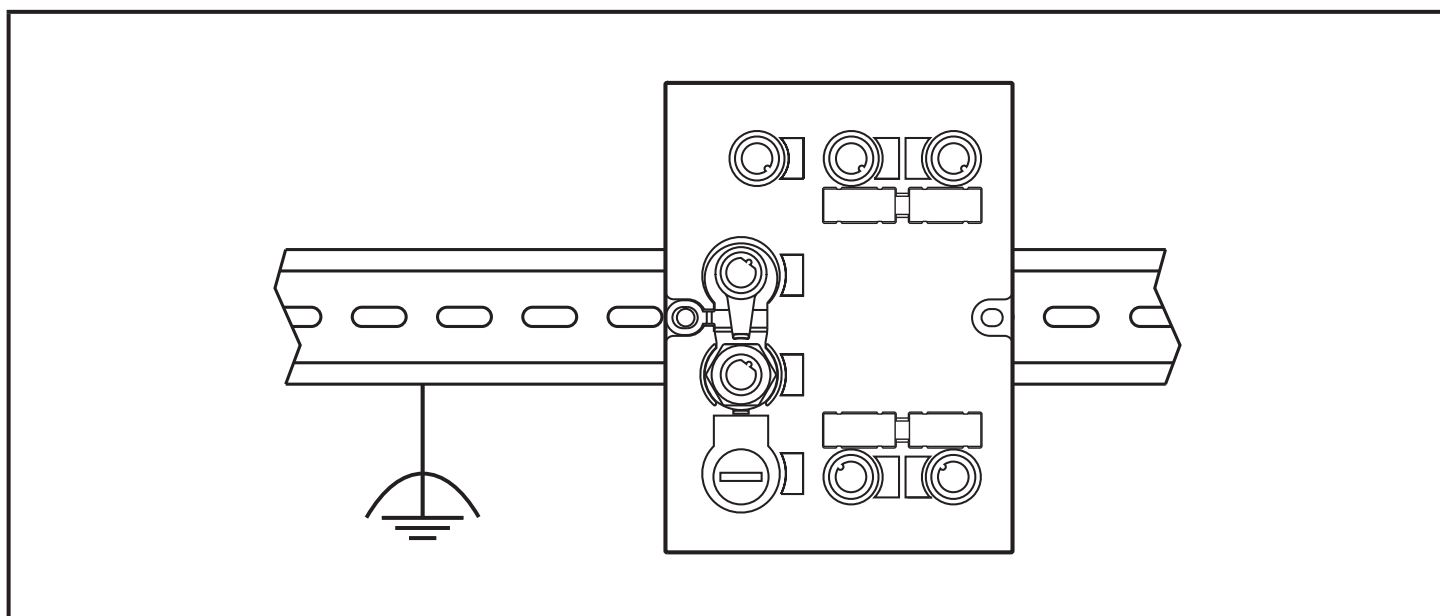

6.4.2 Mounting plate

When the device is fixed on a mounting plate, connection is made via the left fixing screw. Note that the plate must be connected with the earth potential.

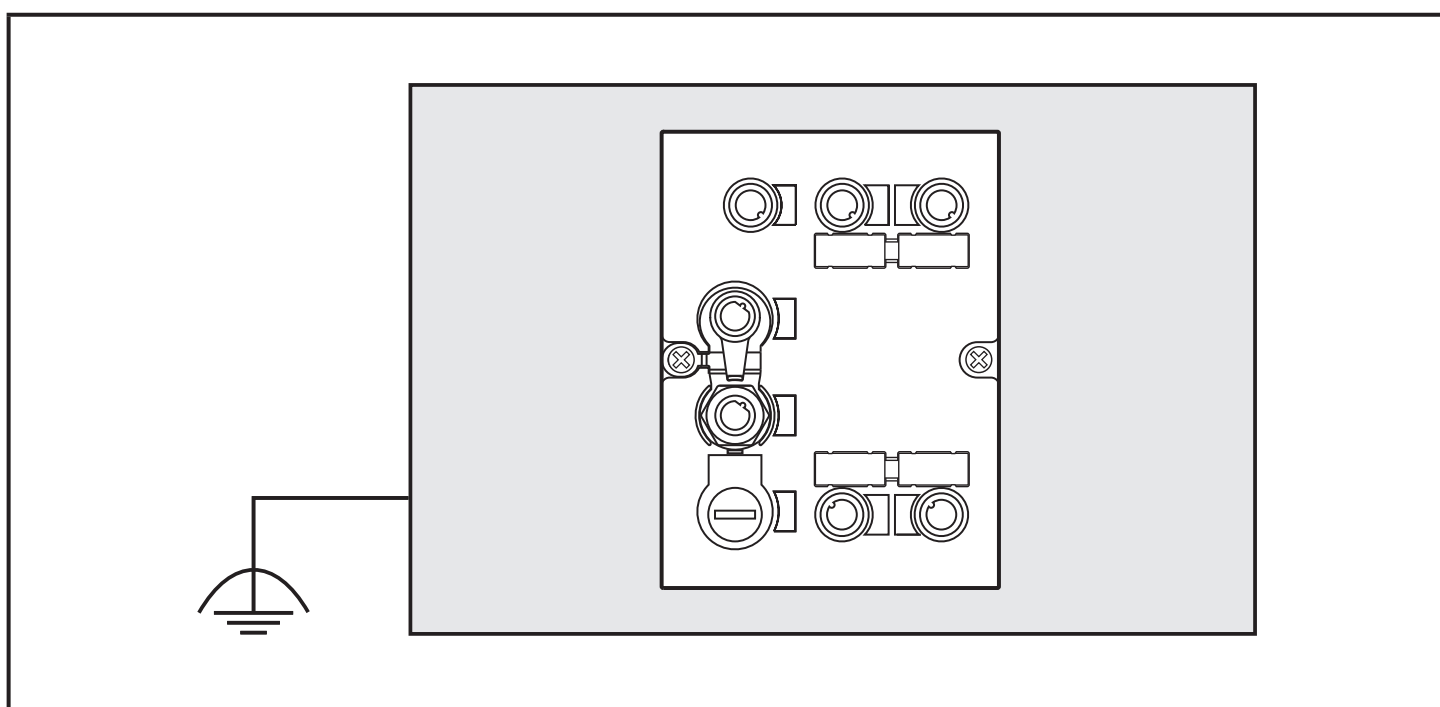

7 Operating and display elements

7.1 Reset to factory settings

The Ethernet parameters can be reset to the factory settings. Take the following steps:

- ▶ Remove all cable connections from the device.
- ▶ Insert an electrically conductive bridge between pin 1 and pin 3 on the process connection IO-3.
- ▶ Connect device with the voltage supply and wait until the yellow LED indication on AUX and IO-3 flashes at approx. 8 Hz.
- ▶ Disconnect the device from the voltage supply and connect it again.
- > The settings are reset.

UK

7.2 LED indicators

The device indicates the current status of the interface via the status LEDs.

7.2.1 LED AUX

LED green	LED yellow	Status	Note
Off	Off	No voltage supply	$U_{AUX} < 5 \text{ V}$
On	Flashes at 2 Hz	Voltage supply too low	$5 \text{ V} \leq U_{AUX} \leq 18 \text{ V}$
On	Off	Voltage supply OK	$18 \text{ V} \leq U_{AUX} \leq 36 \text{ V}$

7.2.2 LED EtherNet/IP Port 1 / Port 2

LED green	LED yellow	Status	Note
Off	Off	No connection to another Ethernet counterpart	Link status "no link"
On	Off	Connection to Ethernet counterpart exists, no data exchange	Link status "link", "no traffic"
On	Flashes sporadically	Connection to Ethernet counterpart exists, data exchange running	Link status "link", "traffic"

7.2.3 LED Mod (module status)

LED red	LED green	Status	Note
Off	Off	No voltage supply	Check the voltage supply.
Off	Flashing	Ready for operation	<p>Device has not yet been configured. There is no exchange of data.</p> <p>Check if the connection was established by the EtherNet/IP scanner.</p> <p>Check if Configuration Assembly was configured.</p>
Off	On	Normal operation	<p>Connection to the EtherNet/IP scanner was established and the device was configured. Data transfer running.</p>
Flashing	Off	Minor error	<p>A connection to the EtherNet/IP scanner could not be established:</p> <ul style="list-style-type: none"> - voltage error - device could not be configured.

LED red	LED green	Status	Note
On	Off	Major error	Software error, hardware error of the device Restart the device. If the error still exists, return the device.
Flashing	Flashing	Self-test	Starting phase of the device

7.2.4 LED Net (network status)

UK

LED red	LED green	Status	Note
Off	Off	No IP address available or no voltage supply	Check the voltage supply. If DHCP is switched on, check if a DHCP server is available in the network.
Off	Flashing	No connection	The device has received an IP address; an EtherNet/IP connection was not established. Check if the device was configured by the EtherNet/IP scanner.
Off	On	Connection exists	At least one EtherNet/IP connection to the device was established.
Flashing	Off	Timeout of the connection	A timeout was found with one of the existing EtherNet/IP connections. Check the status of the connection in the EtherNet/IP scanner.

LED red	LED green	Status	Note
On	Off	IP address exists already	The same IP address as that of the device was detected in the EtherNet/IP network. Check if DHCP is switched off and a static IP address was assigned which is already used in the network.
Flashing	Flashing	Self-test	Starting phase of the device.

7.2.5 LEDs IO1 ... IO4

The LED indications of the process connections differ with each connection configuration.

Use as input to IEC 61131

LED green	LED yellow	Status	Note
Off	Off	Interface deactivated	Interface in EtherNet/IP master not configured
On	Off	Interface activated, input on L level (0 V)	-
On	On	Interface activated, input on H level (24 V)	-
Flashes at 8 Hz	Flashes at 8 Hz	Overload or short circuit	-

Use as output to IEC 61131

LED green	LED yellow	Status	Note
Off	Off	Interface deactivated	Interface in EtherNet/IP master not configured
On	Off	Interface activated, output L-active (0 V)	-
On	On	Interface activated, output H-active (24 V)	-
Flashes at 8 Hz	Flashes at 8 Hz	Overload or short circuit	-

UK

Use with RFID read/write heads

LED green	LED yellow	Status	Note
Off	Off	Interface deactivated	Interface in EtherNet/IP master not configured
Flashes at 2 Hz	Off	Interface activated, antenna off	-
On	Off	Interface activated, tag not in the field	-
On	On	Interface activated, tag in the field	-
Flashes at 8 Hz	Flashes at 8 Hz	Overload, short-circuit or communication error	-

7.2.6 Special device- LED indications

LED	Status	Note
Green AUX LED on Yellow AUX LED flashes at 8 Hz Yellow IO1...IO4 LEDs flash at 8 Hz	Device is in the service mode "emergency system started".	A firmware update is necessary and can be executed via the web server.
Green AUX LED on Yellow AUX LED flashes at 8 Hz Green IO1...IO4 LEDs flash at 8 Hz Yellow IO1...IO4 LEDs flash at 8 Hz	Major error, device has to be returned.	Hardware fault or permanent data in the device are corrupt.
Green AUX LED on Yellow AUX LED Flashes at 8 Hz Yellow IO3 LED flashes at 8 Hz	Reset to factory settings	-

8 Technical data

8.1 Data sheets

Data sheets can be found at:

www.ifm.com → data sheet search → DTE102

8.2 Device manual

The device manual can be found at:

www.ifm.com → data sheet search → DTE102 → operating instructions

9 Maintenance, repair and disposal

- ▶ Dispose of the device in accordance with the national environmental regulations.

10 Approvals/standards

The EC declaration of conformity and approvals can be found at:

www.ifm.com → data sheet search → DTE102 → Approvals

11 Scale drawing

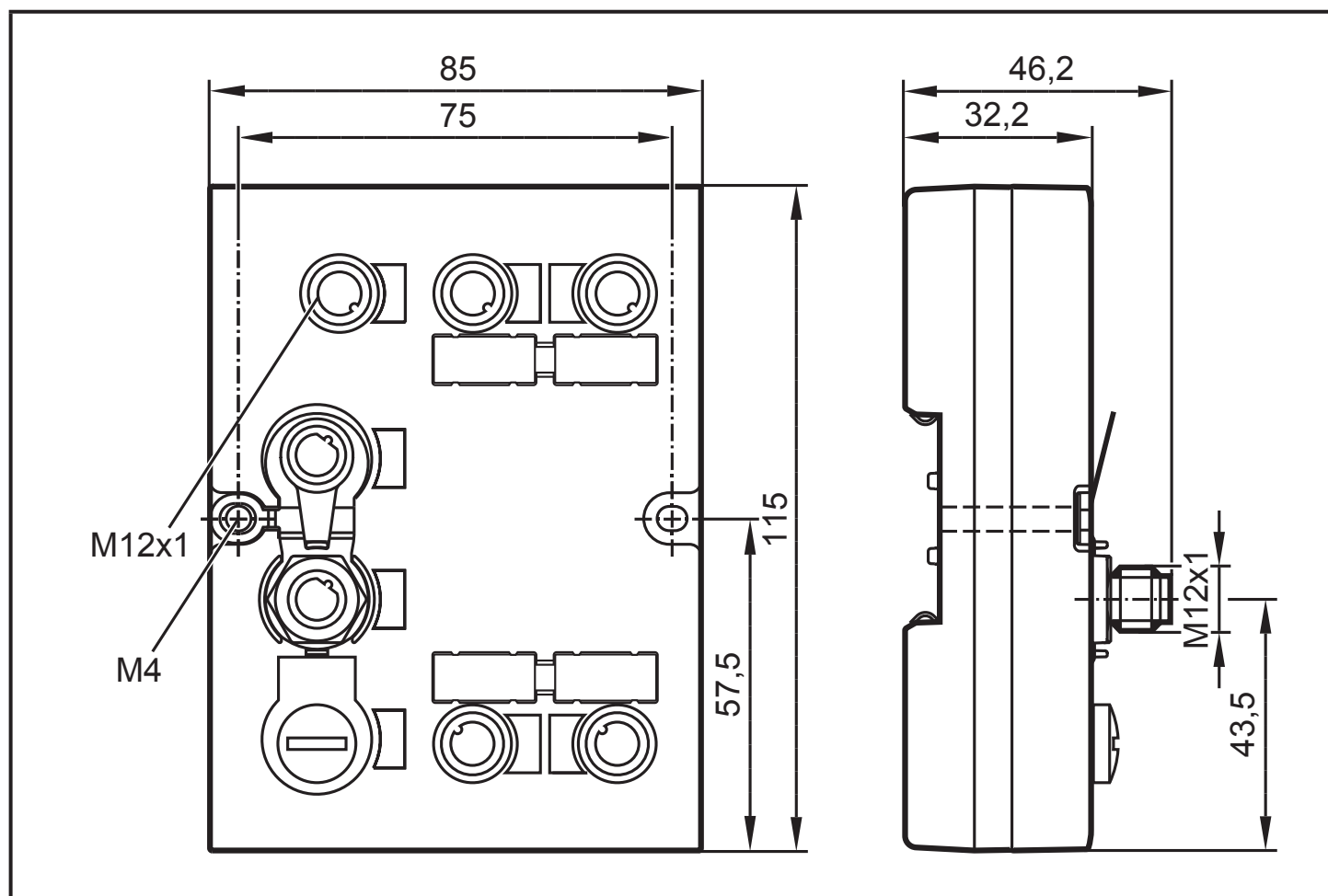

UK