



Industrial communication

SafeLine SmartPLC: fail-safe automation system



AS-Interface Safety at Work



Quick and easy set-up

**Flexible and future-proof
thanks to connective hardware
and CODESYS V3**

**High machine uptime due
to sophisticated diagnostics**

Safe up to SIL 3, PL e

**Unbeatable
price / performance ratio**

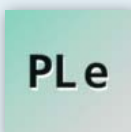

All-in-one: more than just a PLC

Just as a smartphone is more than just a phone, the new SmartPLC is more than just a simple PLC. It has the flexibility for different tasks, even in safety-related applications up to SIL 3, PL e.

For example as:

- fail-safe PLC
- standard PLC
- AS-i gateway
- visualisation system
- protocol converter
- data logger
- intelligent evaluation unit (ifm system solutions)

Two integrated PLCs (1 x fail-safe, 1 x standard), powerful processors, a large memory and a multitude of supported protocols allow the control of sophisticated systems – and this at an unbeatable price!



All-in-one

The new SmartPLC combines two separate PLCs in one compact housing. While the one PLC solves safety-related applications, the second PLC either works as a standard PLC or as platform for other tasks.

Both PLCs communicate with each other, so that entire plant controls can be implemented including safety functions and visualisations with only one SmartPLC.

Products

Type	Description	Order no.
SmartSPS SafeLine		
	SmartSPS SafeLine, 2 x AS-i, Profinet-Device	AC402S
	SmartSPS SafeLine, 2 x AS-i, Profibus-Slave	AC412S
	SmartSPS SafeLine, 2 x AS-i, EtherNet/IP-Device	AC422S
	SmartSPS SafeLine, 2 x AS-i, EtherCAT-Slave	AC432S

Dimensions

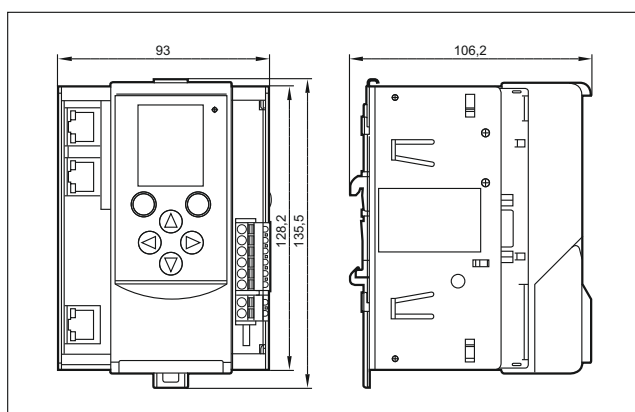

Accessories

Type	Description	Order no.
	AS-i data decoupling module	AC1250

Safe PLC

Certified up to SIL3, PL e. Eight safe local inputs and four safe local outputs. In addition to the AS-i and the local inputs and outputs I/O (standard and safe) can be expanded via EtherCAT + FSoE. Furthermore several SmartPLC SafeLine devices can be linked via the fail-safe cross communication.

Convenient diagnostic functions, include status indication for safe I/Os and error memory with time stamp for up to 2,000 messages.

Programming is done via CODESYS V3. The auto-teach function simplifies the replacement of slaves.

Standard PLC

The PLC can be freely programmed using CODESYS V3. Its software and hardware operates independently of the fail-safe PLC, but it can of course communicate with it and exchange data. The PLC has access to all interfaces of the system.

AS-i gateway

Without programming, the SmartPLC can be used directly as a gateway for AS-i on the one side, and Profinet, Profibus, EtherNet/IP or EtherCAT on the other side. The integrated display and the convenient web interface display all the available status information for the user and support diagnostics in case of a fault.

Data logger

Operational system data can be recorded via AS-i, Modbus TCP, Profinet, EtherNet/IP, EtherCAT, TCP/IP, UDP/IP and stored on the SD card or in the internal flash memory.

If needed, the integrated real-time clock provides a time stamp for each recorded data block. This simplifies the documentation and diagnostics of processes.

Visualisation system

A freely programmable web visualisation based on HTML5 provides maximum transparency. An internet browser with HTML5 capability is sufficient on the final unit (PC, tablet, smartphone). No further software is required. Even the full graphic display of the SmartPLC is freely programmable for visualisation tasks.

Protocol converter

Connect your sensors and Ethernet based devices to your fieldbus: The SmartPLC can be used as protocol converter between Profinet, Profibus, EtherNet/IP, EtherCAT on the one side and AS-i, EtherNet/IP, EtherCAT, Modbus TCP, TCP/IP, UDP/IP on the other side.